

**TO SHELTER THE ENLISTED MAN:
A STUDY OF THE CONSTRUCTION OF
OTHER RANKS' TENTS DURING THE
AMERICAN WAR FOR INDEPENDENCE**



**James Mullins, 2nd Virginia Regiment
Todd Post, 2nd Virginia Regiment
Steven Rayner
Gregory Theberge, H.M. 63rd Regiment of Foot**

A TENT FOR EVERY MESS

During the American War for Independence, each company within a Continental or British Regiment was broken down into individual groups of 5 to 6 soldiers. These groups were collectively known as “messes”. In order to simplify the everyday routines of army life, military regulations of the day required that the men of these messes would prepare and eat their meals together as well as sleep as a common group. In order to do this during a campaign season, each mess was issued a tin kettle from their regimental stores. In many cases, a bag to transport these kettles was also issued. Each mess was also assigned a common tent if, and when, tents were available in the field. With this in mind, it was the mess, the most basic unit of an 18th century army, which greatly influenced the size, shape, and construction of the tents which saw service during the American War for Independence.

In order to cover a 5 man mess, as well as their accoutrements (less their firearms which were often stored in Bell Tents), Lewis Lochee reports that the average size of an enlisted man’s (a.k.a. “Other Ranks”) tent in the British army was 7 feet long by 6 feet tall.

Lewis Lochee, “Essay on Castremetation”, 1778

“The Tents which are of various sorts and forms, serve to lodge and protect the troops against the inclemency of the weather; those of the private men are made of strong cloth, and are large enough to lodge 5 men.”

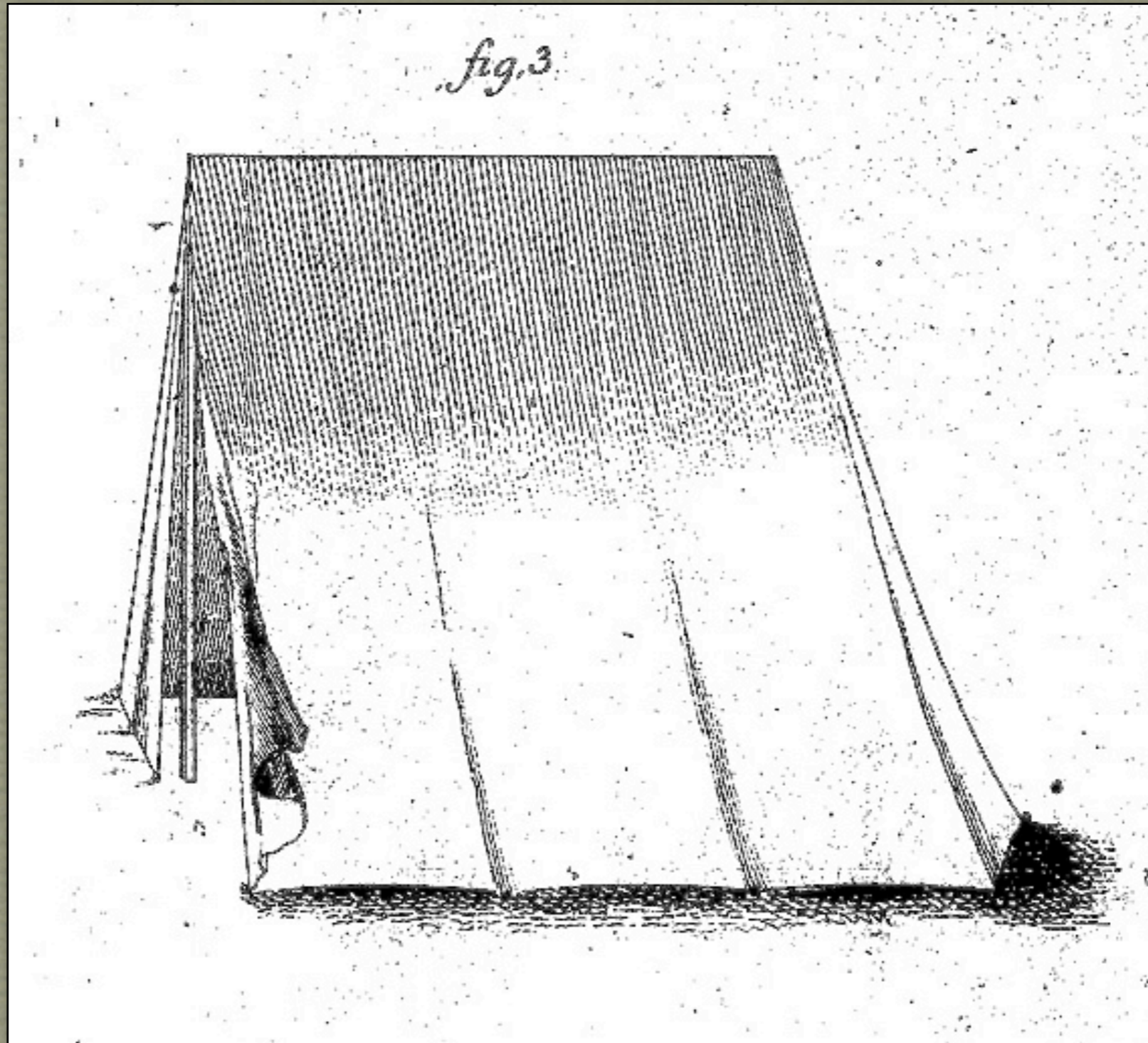

Detail from Lewis Lochee “An Essay On Castrametation” 1778

British Other Ranks' Tent
Revealing 3 Side Panel Construction, with 2 Panel Front Flaps, and a Bell Back

Lewis Lochee, "Essay on Castremetation", 1778

"These tents are fixed by means of three poles and thirteen pegs: The poles A are called **Standard Poles**, and are about 6 feet high; the pole B is called **Ridge Pole**, and is about 7 feet long: The ridge and standard poles are held together by **two iron pins**, fixed in the top of the standard poles."

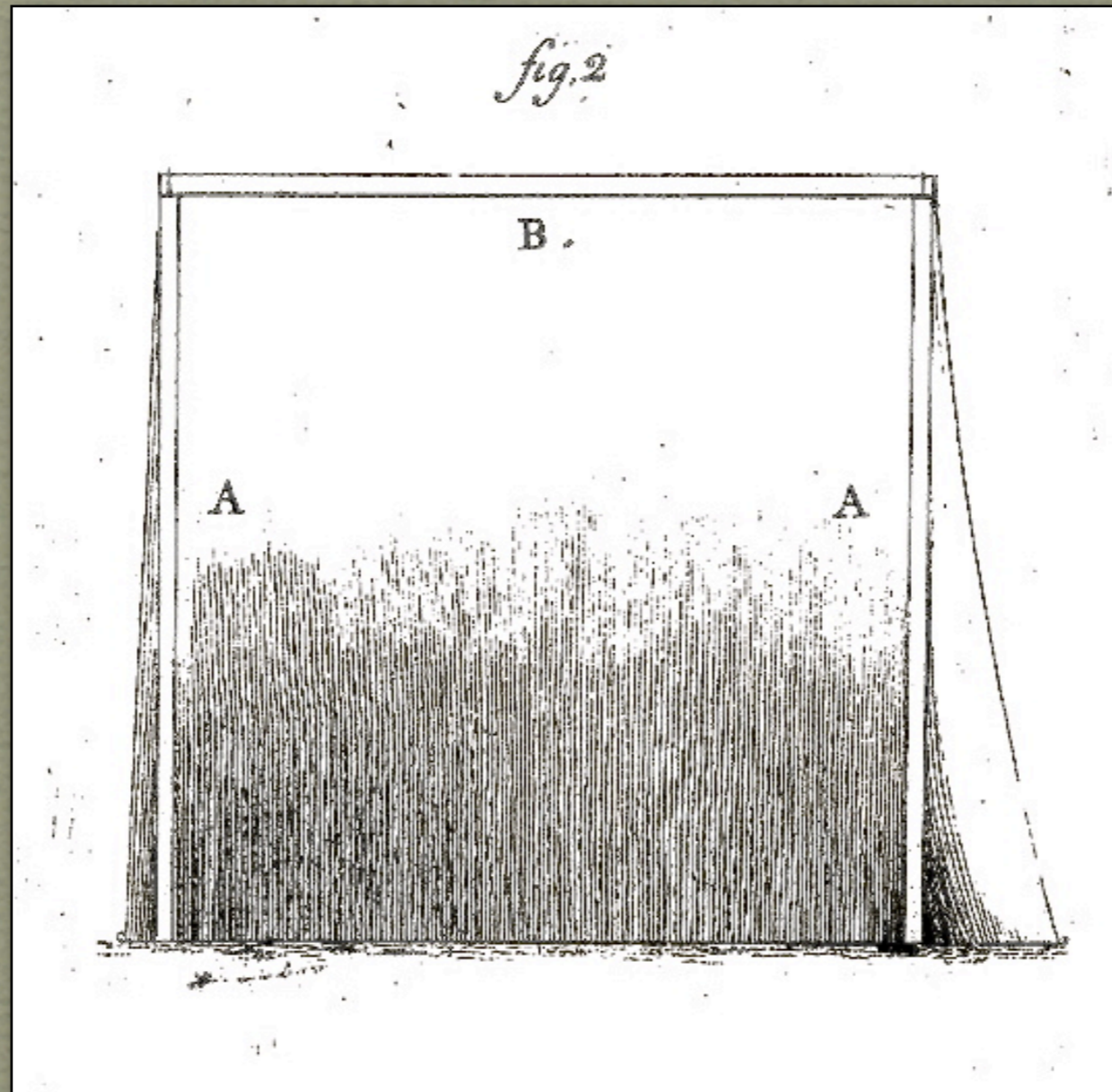

Detail from Lewis Lochee "An Essay On Castrametation" 1778

What is interesting is that these dimensions of British Army tents were the same as they were when the New Model Army was operating in the mid 17th Century:

3 Aprilis 1645

“Tents for the Trayne 200 of John Snow Tentmaker the Tents vii^{en} foote long vii^{en} foote broad and six foote high of good Lockeram according to the pattern & wth firre staves lynes & pinns & other appurtenances according to ye best Trench Tents at xx^s p Tent” (M-4)

In 1779, Captain George Smith reports different dimensions to an other ranks' tent:

“The tents of private men are 6 1/2 feet square and 5 feet high, and hold 5 soldiers each” (S-5)

Unlike their British counterparts, the size of a Continental Army tent often varied throughout the course of the war. These tents were ideally built to accommodate a mess of six men. Later in the war, they were to shelter up to 7 or 8 men.

June 1776

Returns for Captain Joseph Bloomfields Company

3rd New Jersey Regiment, Continental Line

“Tents to be Drawn for ... 72 Soldiers, which is 12 Tents allowing Six men to a tent.”

Orderly Book of the Pennsylvania State Regiment.

“Head Quarters Fort Mercer May 24th 1777...

Regular Division of Tents to be made according to ye number of men in each

Company - one tent for six men or 5 men and one woman...” (need bibliography, p. 58.)

At times, Continental Army tents were too small to accommodate a full mess of men. This could have been due to a variety of reasons. First, there were the contractors. Quite frequently, these men were sailmakers who did not necessarily have any set standards to go by. Secondly, in certain cases, it may have been due to the tent manufacturing process itself. To be discussed later, there is evidence that some tents were sewn utilizing a selvedge edge seam technique. Depending on the width of the canvas used, tents could have varied if the selvedge edge of the cloth dictated the location of the seams.

Quartermaster General Timothy Pickering

*'Since the army took the field I have heard great complaints of the smallness of the tents. The new common tents are not too big for four Men: upwards of 400 were made before my Appointment... The same **sail maker** I suppose have made those sent only you, which tho of very good stuff yet are ruined by the smallness of their size... Some old common tents were from 7 to 7 1/2 feet square on the ground. The ends of the new tents Complained of are little more than five feet broad. It seems that the various descriptions of tents have been misunderstood.'* (need bibliography - national archives?)

On October 10, 1776 the Connecticut Assembly resolved:

*"That each Tent ordered to be made by this Assembly... shall contain the quantity of twenty-seven yards of cloth, **one yard wide**, or equal thereto in **cloth of different width**, well manufactured of yarn not coarser than thirty knots to the pound;" (H-2)*

In 1781, however, Quartermaster General Timothy Pickering attempted to “standardize” the *minimum* dimensions of the tents used by the Continental Army. He recommended that:

"A common, or soldier's tent should be at least 7 feet square, larger a little if it happens to suit the breath of the cloath." and should be *"7 feet square and 7 Feet Height."* (W-2)

Once again, this implies that the length of these tents could vary depending on the width of the canvas available for their fabrication.



A detail of Charles Wilson Peale’s portrait of Colonel Walter Stewart of The Pennsylvania Line revealing a typical Regimental Camp layout of the Continental Line. Note the musket rack, sparseness of the camp, as well as the individual kitchen and possible Quarter Guard with sentry at the tree line.

TENT AND SAIL CLOTH

According to current research, the fabric and techniques utilized to produce other ranks' tents during the American War for Independence was frequently similar to that used in the production of sails during the 18th century. In fact, sailmakers were often contracted to produce military tents.

Nathanael Greene to Captain Maberly:

December 4, 1780 (Year Uncertain)

“All the sail and tent makers will be sent to you tomorrow. You will make up the sail and raven's duck into common tents.” (G-1, p.79)

Likewise, the tools that were required to sew sails were also utilized in the fabrication of tents. Although he is referencing Officer's Marquis, Timothy Pickering, Quarter Master General of the American Army, confirms this.

Timothy Pickering, General Quartermaster's Return, April 1, 1782

“Return of all Public Property belonging to the Quarter Master General Department from Massachusetts to Pennsylvania & with the Main Army Species of Property....

Materials & Spare Furniture...

Marquee {Hooks

_____ {Tops...

Tent Buttons

Marquee Balls

Tent Pole Rings

Horsemans do.

Tent Sliders

Hanks Tent Cord...

Palm Irons

Sail Needles

Sailmakers Hooks...”

(W-2, p. 16)

Fabric utilized in the production of enlisted men's tents was traditionally 12 to 16 ounces per square yard (on average) with a thread count roughly of 29 x 25-30 x 32 ends per inch. For an other ranks' tent, the cloth had a Plain Weave. As an aside, there are some period examples of an Officer's Marquee (or portions thereof) being made out of a Herringbone Patterned cloth.

While no resource specifically mentions the color of the cloth used for tents, one period source states that it was Bleached. It is also quite possible that tent cloth was simply left in its natural (light brown) state which, over time, would bleach with exposure to the sun.

Depending on the reference, 18th Century Military Tent cloth was made of any of the following materials. Some differed by name alone.

1. “Duck”, “Russia Duck,” or “Raven Duck”

“Duck”, or “Dutch Duck”, was defined by Richard Rolt in 1761 as “**a kind of Dutch sail cloth....sail cloth...is a particular sort of cloth, or canvas, made of hemp.**” Rolt also refers to a statute of George II stipulating that both hemp and flax was used for sail cloth (Duck), but the yarn used “should be well cleansed, even spun, and well twisted”. More contemporary source refers to it as “strong, thick linen cloth, finer and lighter than canvas” (M-3)

To General Nathanael Greene.

“Newport, Nov. 6th, 1779...

Sir, your favour of the 30th ult. I received, and have, as you wished, laid hold of every piece of duck in the town, which is only eleven of Russia and five of Raven’s, which are now making into tents...

E. Bowen, D. Q. M. G.” (S-3, p. 248)



An Example of Extant Unbleached 18th Century Dutch Duck Tent Cloth
“Taft Duuk”



A Detail taken From David Morier's Painting of the British Grenadiers of the 19th and 20th Regiments of Foot as well as 21st Royal North British Fusiliers.

In this view, an Other Ranks' Tent made of Dark Brown Cloth, probably Unbleached Linen, can be seen.

c. 1751-1760

(The Royal Collection)

An order of Congress to P. Curtenius to purchase and fill a requisition for supplying the Continental Army:

'Amount of sundries, as per the order of Congress, of the 26th of February, 1776, and sundry other orders, viz.:...

	£	s	d
12 field officer's tents, at about £25,	300	0	0...
32 captain's tents,			
32 lieutenant's tents,			
16 ensign's tents,			
4 adjutant's tents. 96, at about £8 each,	768	0	0
4 quartermaster's tents,			
4 chaplain's tents,			
4 surgeon's tents,			
108 valises at about 40s.	216	0	0
108 tent bags at 5s.	27	0	0
450 soldier's tents at about 80s,	1832	0	0

*(The price depends on the price of duck. If I must give £5 10s for raven's duck they will cost full what I have estimated. A square tent takes a piece of **duck**, and making 32s. A soldier's, 21 yards at 3s per yard, and making 10s. P. T. C.)'*" (H-3, p. 487)

Here, we can see that an individual soldier's tent took 21 yards of "duck". We can also get an idea on the quantity of tent cloth required to furnish a company with tents:

Captain John Floyd to Col. William Preston

Sept. 18th 1774...

I am in hopes we shall make out pretty well about kettles we are also allowed 60 yards of tent cloth for a company.." (K-1)

On the Manufacture of Sail Cloth in Scotland:

Thomas Pennant, Montrose, Scotland, 1772:

“The town has increased one-third since the year 1745; at that time there was not a single manufacture: the inhabitants either lived by one another, or by the hiring out of ships, or by the salmon trade. At present the manufactures have risen to a great pitch: for example, that of sailcloth, or ‘sailduck,’ as it is here called, is very considerable; in one house, eighty-two thousand five hundred and sixty-six pieces have been made since 1755. Each piece is thirty-eight yards long, and numbered from eight to one. No. eight weighs twenty-four pounds, and every piece, down to no. one, gains three pounds in the piece. The thread for this cloth is spun here, not by common wheel, but by the hands. Women are employed, who have the flax placed round their wastes, twist a thread with each hand as they recede from a wheel, turned by a boy at the end of a great room.”

Extrapolating from Pennant’s description:

No. 1 - 45 lbs.

No. 2 - 42

No. 3 - 39

No. 4 - 36

No. 5 - 33

No. 6 - 30

No. 7 - 27

No. 8 - 24, per Pennant.

Width unknown.

(P-2, p. 499)

Although the following account by Isaac Titford is dated 7 years after the surrender of Cornwallis at Yorktown, it nonetheless sheds some light on the manufacturing process of sail-cloth in Boston in 1790. While it may not exactly pertain to the fabrication of sail-cloth during the American Revolution, it does reveal that English sail-cloth was **STARCHED** during this period.

Isaac Titford, in a letter of December 26, 1790:

“I am lately returned from the continent of North America, and beg leave to mention the two following remarks I made at Boston, although I must conceive them known to the Society; yet their importance will, I am sure, excuse the mentioning them to you.

*In their sail-cloth or **Duck** manufactory, which they carry on with great spirit, they publicly allege that theirs is superior to the British sailcloth, from its never being subject to mildew, which I understand is very pernicious to its wear. I observed that their weavers wet or moisten their warp in the loom, with a **decoction or jelly-like substance, made of the remains of Neat-feet, after the oil is expressed from them, and which then is of no farther use: this residuum is boiled to a jelly, or kind of glue, and used by them instead of starch made with flour and water, commonly used, if I am rightly informed, by sail-cloth manufacturers in England.**”*

(need bibliography p. 184-85. (transactions of the society))

Arthur Young also elaborated on both **BLEACHING** and **STARCHING** sail-cloth during the manufacturing process in his 1771 “A Six Months Tour through the North of England” :

Manufactures at Warrington, Cheshire.

*“At -Warrington,- the manufactures of sail-cloth and sacking are very considerable. The first is spun by women and girls, who earn about 2 d. a day. It is then **bleached**, which is done by men, who earn 10 s. a week; after bleaching it is wound by women, whose earnings are 2 s. 6 d. a week; next it is warped by men, who earn 7 s. a week; and then starched, the earnings, 10 s. 6 d. a week. The last operation is the weaving, in which the men earn 9 s. the women 5 s. and boys 3 s. 6 d. a week.*

*The spinners in the sacking branch earn 6 s. a week, women; then it is wound on bobbins by women and children, whose earnings are 4 d. a day’ then the **starchers** take it, they earn 6 s. a week; after which it is wove by men, at 9 s. a week. The sail-cloth about three hundred weavers, and the sacking an hundred and fifty; and they reckon twenty spinners and two or three other hands to a weaver.*

During the war (the Seven Years War, author’s addition) the sail-cloth branch was very brisk, grew a little faint upon the peace, but is now, and has been for some time, pretty well recovered, though not to be so good as in the war. The sacking manufacture was also better in the war; but is always brisk.

The spinners never stand still for want of work; they always have it if they please; but weavers sometimes are idle for want of yarn, which, considering the number of poor within reach, (the spinners of the sacking live chiefly in /Cheshire/,) is melancholy to think of.”

(Y-1, p. 164)

In Lord John Sheffield's 1784 "Observations on the Commerce of the American States," we gain some further insights on Russian and Raven Duck sail-cloth:

"Sail-Cloth of every kind is imported by the American States. Russia had the advantage in Russia-duck and Raven-duck, but, when charged with the duty on importation here, they were as dear as the British sail-cloth. lately, the exportation from hence of of Russia sail-cloth for America has almost ceased. Russia-duck in England is about 6s. per piece (of 36 yards) dearer than in Holland, arising from duties and other expenses, which, as far as it will not interfere with our own linen manufactures, should be lowered.

In the Spring of the present year, 1783, Russia-duck was so scarce in England, that near 3l. was given for a piece that formerly sold from 35s. to 40s. This occasioned a great demand for British sail-cloth, which has a bounty of 2d. per ell on exportation. A duty of 2l. 1s. 8 1/2d. is payable on importation of 120 ells, or 150 yards of Russia-duck or sail-cloth, no part of which is drawn back upon exportation, either to any British colony, or to any other parts whatever. It is considerably wider than English.

The number of pieces of sail-cloth exported from Petersburg for five years, was as follows:

	1774	1775	1776	1777	1778
<i>Pieces in Eng. ships</i>	11580	6757	2659	1505	401
<i>Do. in foreign ships</i>	25187	28397	38660	44156	37663
	-----	-----	-----	-----	-----
<i>Tot. numb. of pieces</i>	36767	35154	41319	45661	38054

The law that obliged all British-built ships to have the first set of sails of British canvas under the penalty of 50l. being now at an end, with regard to the ships of the American States, there will be competition for this article. Of late years considerable improvements have been made in the various species of sail-cloth in Scotland, and the price is considerably reduced, in consequence of the facility with which hemp can be brought from the Baltic, and the low price of labour in the north of Scotland. It will be in the interest of the Americans to take British sail-cloth while the present bounty is continued.

It is said, British sail-cloth is more apt to mildew; but that may be prevented, in a great measure, by pickling when new; it is also said, that the Russia sail-cloth is more pliable. France makes sail-cloth, but is much dearer and inferior. Some has been made at Philadelphia, but the quantity must be trifling." (S-2)

2. “Osnaburg”

Col. William Christian to Col. William Preston

“Camp Union Septr. 12, 1774...

*The kettles and Tents were chiefly distributed before I came I could get but 16 or 17 battered tin kettles for all Fincastle & but few Tents But I am told **oxen brigs** [unknown doodle] enough for Tents will be brought with the Pack horses to morrow If the major is not marched when you get this Intelligence I really think we ough[t] to send over the whole Country and try to beg or borrow kettles for to do without is very hard almost [im]possible It will presently make men sick to live on Roasted meat without broath.” (T-1, p. 198)*

Col. Richard Henderson

“Fort Boone, on the mouth of Otter Creek, Cantuckey River...” (H-4, p. 221)

“Friday, 5th. [May, 1775.]... Let Mr. Wm. Cocke have five yards and a half oznaburgs off my old tent, for which I charge him 5s. 6d. V. money.” (H-4, p. 225)

From various accounts, we can determine that osnaburg tents had their limitations when retarding the elements:

1760 (Pre-war):

Captain Samuel Jenks of Chelsea, Massachusetts:

“Thirsday, 4th Sept. [1760. Six miles from Chamblee, Canada.] Last night I had my tent pitcht & fixed so that I lay quite well... we shall soon I hope, be mouing homeward, for it begins to be cold nights, & our oznabrig tabernacles is but poor shelter for this cold climate.” (M-3, p. 375)

1778:

Henry Hudson, in a letter from Rhode Island, October 14, 1778.

“It would be pretty tolerable, if it was fair weather all the time, but these oznabrig houses are not so clever in rainy weather.” (C-4, p. 409)

1791 (Post-war):

Captain Samuel Newman, 2nd United States Regiment. St. Clair’s Campaign:

“Saturday Septr. 24th [1791].

Rainy, stormy morning. rain’d all Day, but absolutely pour’d in sheets & torrents all night! Tent, bed & Clothes Wet, d--d the Economy of the Contractor who for thinness of our Tents, particularly the backs & doors which are made of very coarse Oznabrigs! & thro! which the rain beat, as if thro! a Sieve! this is the Country cheated, and the Soldier imposed on...” (Q-1, p. 64)

3. "Ticklenburg"

*"Williamsburg May 17, 1777
Commonwealth ... D
To 20 Ps Ticklenburg 2681 1/4 Yds.
deliv'd W. Davenport for makg
Tents for the soldiery belonging
to this State: also 12 ll brown
Thr.d @ 8/6 for making up the said linen
Rec'd by [signed] Amb— Davenport" (W-3)*

*"List of Camp Equipage Military Stores, Baggage &c. taken in the Brig. Symetry Capt.
[Blank.] at Wilmington Jan: 1778.-...
Sent to Faggs
Manor Meeting house
230 New Ticklenburg Tents...
117 worn do. fit for use
38 old ditto...
Moor Hall Jan. 10 1778" (W-2)*

*"Tuesday, June 13, 1780...
That the board of admiralty take order for supplying the quartermaster general with such quantity
of the duck and ticklenberg belonging to the United States, in possession of the **navy** board at
Boston, as he may have occasion for, to compleat the number of tents wanting for the army, and
which can be spared from the immediate use of the navy." (C-2, p.175)*

According to this account, it is apparent that the cloth to be used for the construction of tents was originally intended to be used for the fabrication of sails for the navy.

4. “Tow Cloth”

*“At a Meeting &c. adjourned from Yesterday. 16 July [1776.]
The Hono. Congress having requested this Colony to furnish our troops with tents,
Cloathing &c.: On consideration voted a committee be appointed to purchase and
procure all the tow cloth and other suitable cloth or materials for making tents that
can be had in the Colony.”* (H-2, p. 482)

*“This Board do appoint Messrs. Andre Huntington, Joshua Elderkin, Cauncey
Whittelsey of Middletown, Jona. Fitch, Saml Squire, and Lynde Lord, a committee to
purchase all the suitable tow cloth and other suitable cloths for tents, to be obtained
in their respective counties, and cause the same to be made up into proper tents for
the use of the troops of this Colony, in the most expeditious manner they can, and
report to his honor of what they shall respectively do in the premises.”* (H-2, p. 483)

Again taking into consideration the relationship of sail and tent cloth, we can gain further insight on tent material by referencing Nautical manuscripts. In David Steel's, "The Elements and Practice of Rigging And Seamanship" (1794) , we see that sail cloth came in a variety of different weights based on a 38 yard long "Bolt" of 24" wide material:

"CANVAS. For the royal navy, canvas or sail-cloth is 24 inches wide; and 38 Yards are called a bolt. To distinguish the different qualities, each bolt is numbered, and should weigh as follows; No. 1, 44 lb. No. 2, 41; No. 3, 38; No. 4, 35; No. 5, 32; No. 6, 29; No. 7, 24; and, No. 8, 21 pounds: from No. 1 to 6 is termed double, and above No. 6 single, canvas." (S-4, p.86)



The Marquee of General George Washington - The American Revolution Center

Detail of General George Washington's Marquee showing the utilization of unbleached linen cloth for the sod flap. Examination of the canopy and walls of this tent reveals that it was originally made from a white and blue striped linen which has faded over time.

EXAMINATION OF AN EXTANT 18TH CENTURY OTHER RANKS' TENT OF THE PRUSSIAN ARMY

Nestled in the hills of Styria, Austria, is a castle by the name of Burg Forchtenstein. Within its walls resides a vast collection of early European military artifacts, a portion of which includes an assortment of rare military tents that saw service in the Prussian Army during the 18th Century. Among these tents is the only known example of an enlisted man's (other ranks') wedge tent to have survived from this time. While it should not be considered an exact representation of either a British or Continental wedge tent during the American War for Independence (unfortunately, none of these tents have survived), it does, nonetheless, provide some extremely important insights into the manner in which a common soldier's tent was constructed during the 18th Century.

In 1975, Ruth Bleckwenn made a study of the tents in the Burg Forchtenstein collection and published her findings in a book entitled "Zelt und Lager im AltPrussischen Heer." ("Tent and Camp in the Old Prussian Army. The Old Prussian Army Appearance and Essence 1713-1807"). As we proceed with the individual details of 18th Century tent construction, this study will be referenced and individual photographs from this work will be shown.



The Caste at Burg Forchtenstein

TENT SEAM CONSTRUCTION

Written orders of the day and examination of extant artifacts reveal that there were, at least, **three** different types of seams used in the manufacturing process of tents during the 18th century. Two of these seam techniques incorporate the selvedge edge of the cloth, much in the same manner in which sails were sewn at the time. These seams were known as either “Round” (otherwise known as “Single”) seams, or “Flat” (otherwise known as “Double”) seams. These techniques in construction obviously required that cloth of a specific width had to be used if a tent was to be fabricated to specific length requirements.

I. THE “ROUND” (SINGLE) SEAM

In William Falconer’s “Dictionary of the Marine” (1780) “Round Sewing” is defined as:

“Round sewing is used where greater strength is required, the stitches passing through four thicknesses of the cloth instead of two. There are two forms, known as single last and double last. In single last, each cloth to be joined has its edge turned in about 1.8 centimetres, the two are then placed together, held taut with a sailmaker's hook, and joined at the edge by passing the needle through all four parts about 3 centimetres from the edge and back over the top, making four stitches every 2.5 centimetres. In double last, the selvedge of one piece of cloth is placed level with the doubled edge of the other and the seam sewn as in the single last. The work is then reversed and the selvedge of the other piece is similarly stitched to the other, which is doubled at the seam line. In round sewing, the direction of sewing is always towards the hook.” (F-1)

During the American War for Independence, we can document that some of the tents fabricated in Baltimore were sewn with **Round Seams** for greater strength (at a greater cost):

*Journal and Correspondence of the Maryland Council of Safety,
July 7: December 31, 1776*

*“To Mr. Samuel Dorsey, Ann Arundel County
Sir. We approve your Patterns for a Tent, but cannot
give the price you ask, one of the Baltimore Tentmakers was
here and says he will make them with a round seam for two
Dollars — if you will make them with such seams on your
moddle, we would have you proceed, otherwise be pleased to
make some agreeable to the Baltimore pattern at twelve
Shillings — if you do not care to make on those terms, send
the Linen you have to Baltimore Town to William Johnson
who has agreed to make at those prices.
The Tent Poles we will pay you for according to the price
given at Baltimore, which we cannot now ascertain...
21 August 1776” (M-1, p.228)*

Although the “Round Seam” was considered stronger, this technique resulted in a thick gathering of cloth on the tent’s exterior (being four layers of cloth). It would also result in the exposure of two loose selvedge edges on the tent’s interior. This thickness most likely gave the seams their “Round” appearance.

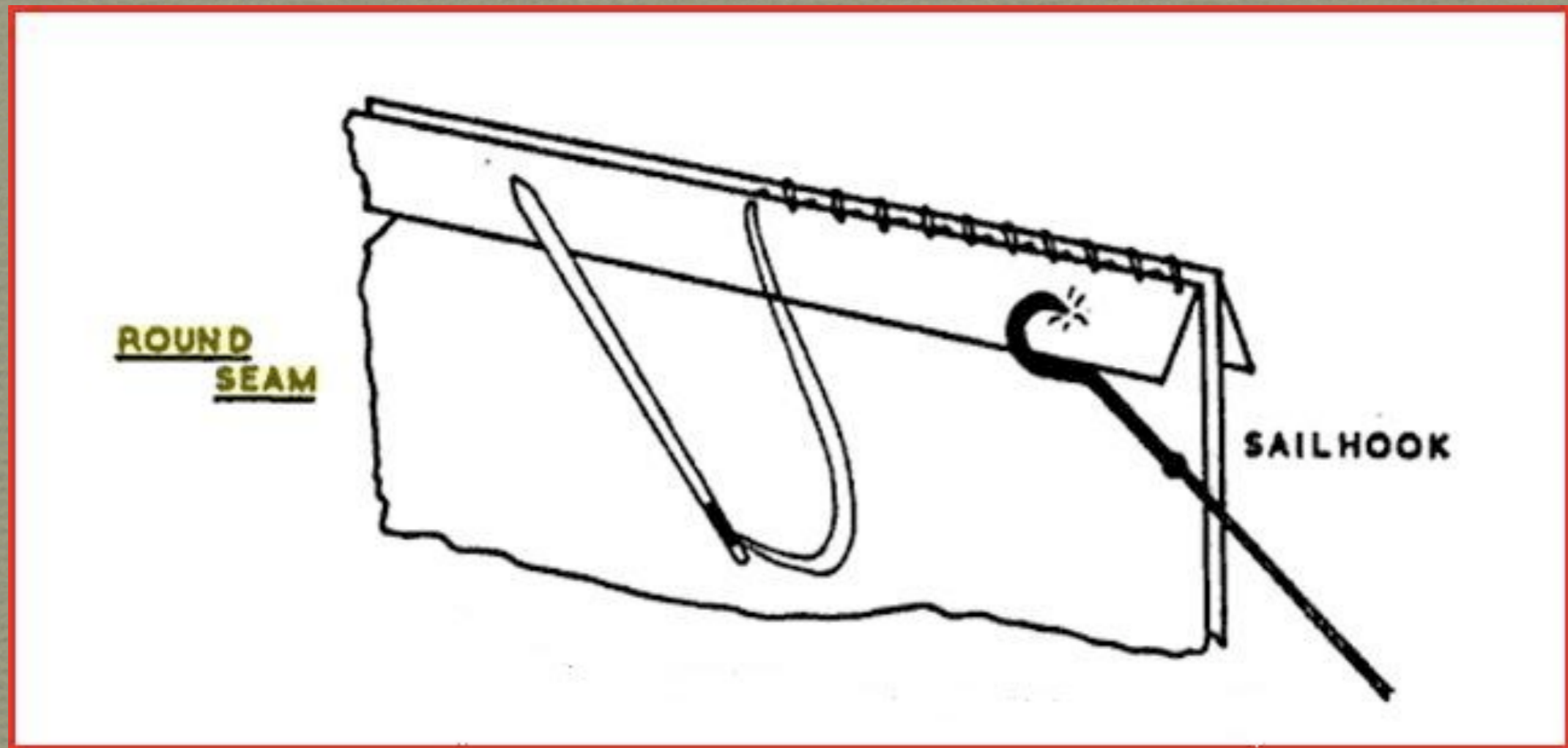

The Round Seam Technique

II. THE “DOUBLE”, “FLAT”, or “MONK” SEAM

David Steel’s, “The Elements and Practice of Rigging And Seamanship,” (1794) sheds light on some important basics on sail and double flat seam construction:

“SEAMS. Sails have a Double Flat Seam, and should be sewed with the best English-made twine of three threads, spun 360 fathoms to the pound, and have from one hundred and eight to one hundred and sixteen stitches in every yard in length.

108 / 36 = 3 stitches per inch.

116 / 36 = 3.22 spi.”

In William Falconer’s “Dictionary of the Marine” (1780), flat seam sewing is described as a seam which did not require as much strength as a round seam:

*“Flat sewing is used to join two pieces of sailcloth or canvas where **strength is not of paramount importance**. The selvedge of one piece of material is placed along the seam line of the other, both are hooked onto a sailmaker's hook to keep them taut, and the needles passed down through the single cloth close to the selvedge and then up through both cloths, and so on until the whole seam is completed, with a back stitch to terminate the line of sewing. The normal spacing is three stitches to 2.5 centimetres (1 in.). When the first seam is completed, the work is reversed and the selvedge of the piece of cloth sewn to the seam line in the same way. The direction of sewing in flat sewing is always away from the hook.”*

Like the Round Seams, we can also document that some tents in Baltimore were sewn with **Double (flat)** seams during the American War for Independence:

Journal of the Maryland Council of Safety:

“Monday 15 July 1776.

The Council contract with William Jacob of Baltimore Town for the making of double seamed Tents at seventeen shillings each and single seamed Tents at twelve shillings each.

Ordered That the Commissary of Stores deliver to William Jacob all the Tenting linen which was delivered into the magazine by Mr Edward Parker of Caecil County...

...C. S. J.

Tuesday 6 August 1776.

The Council contract with Samuel Dorsey of Elk Ridge for the making of Tents, double seamed at 17/ each, and single ditto at 12/ each.” (M-1, p. 174-175)

THE MONK SEAM (1764)

A monk seam was essentially a nautical term which described the Double Seam:

“Monk Seam... among Sailors, is the sewing the edges or selvages of sails together, over one another on both sides, to make it the stronger.” (B-1)

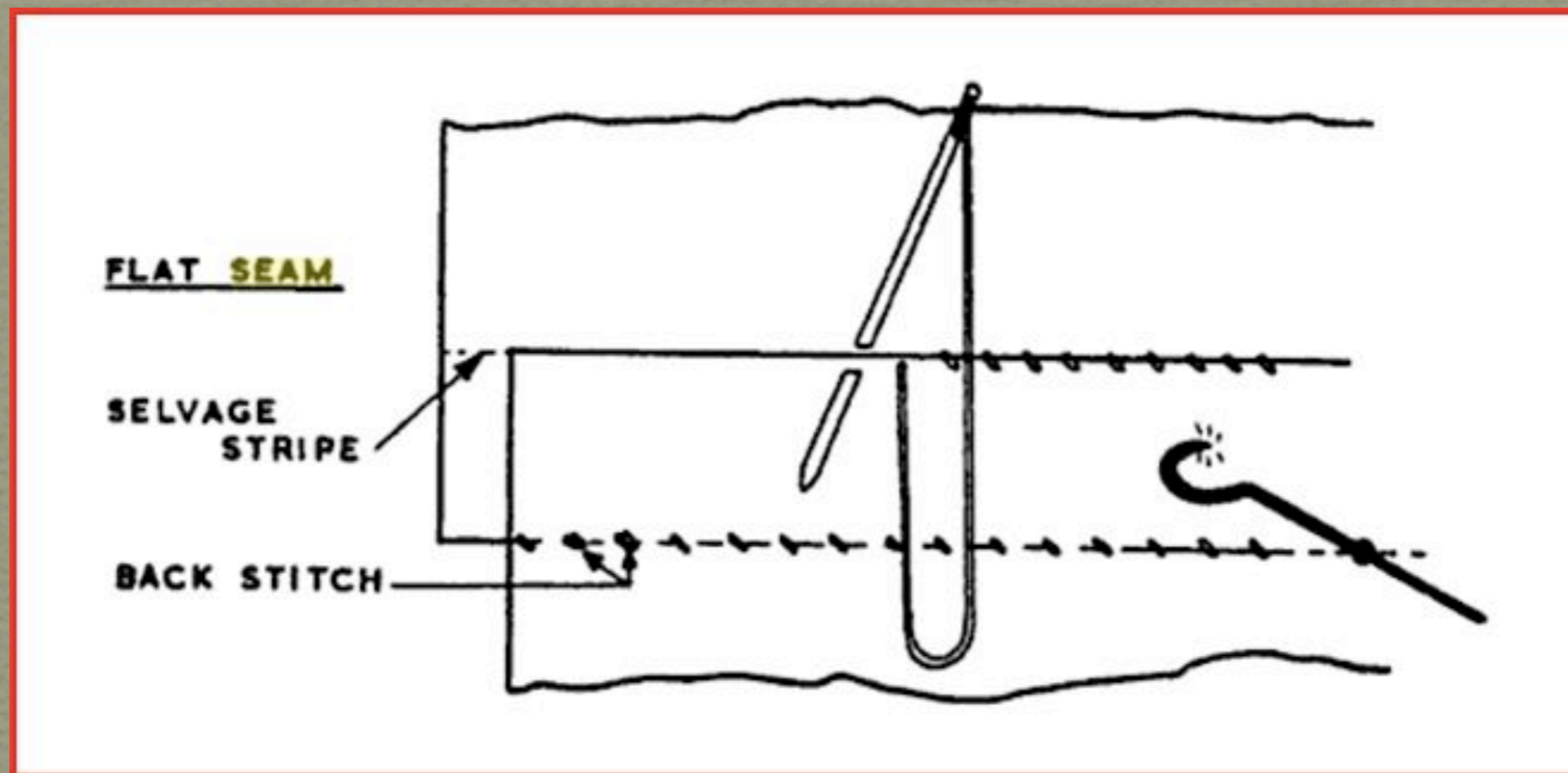

The Double, or Flat, Seam Technique

III. THE “BACKSTITCH” / FELLED SEAM

The third type of seam used in 18th century tent construction actually comes from an examination of both the extant Prussian tents in the Castle at Burg Forchtenstein as well as the Marquee of General George Washington now on display at the American Revolution Center located in Philadelphia, Pennsylvania.

While the evidence gathered from examining a photograph in a book is far from conclusive, it does not appear that the extant Prussian tents are sewn with either a Single or Double seam technique. They do not have the appearance of being round, nor do they appear to be sewn with two rows of visible stitching. Instead, these seams appear to mimic that of 18th century clothing. It is quite possible that they were fabricated with a back stitch. This technique results in only the seam itself being visible and perhaps one row of visible stitching as a result of overcasting. Unfortunately, most of the pictorial evidence we have of this tent's seams is that of an interior lining (which will be discussed later). As such, an absolutely definitive “conclusion” cannot be ascertained, but a reasonable estimate can be rationalized.

On the other hand, an examination of General Washington's Marquee quite definitively confirms that a backstitch technique was used to fabricate the side panel seams of this tent. While it is certainly not an other ranks' tent, this Marquee shows conclusive evidence that this technique was used by tentmakers of the period. Unlike a “Round” or “Flat” seam which utilizes the selvedge of the tent cloth, these seams were clearly sewn with cloth which was folded over and overcast in place. Unlike sewing tents with a selvedge edge seam, this manner of seam construction gave more leeway in the width of cloth that could be utilized in tent fabrication. Close examination of these seams reveals they were sewn with a double thread.

Seam Widths:

Wall Seams: 1.5 - 2 cm

Base Seam: 5 cm

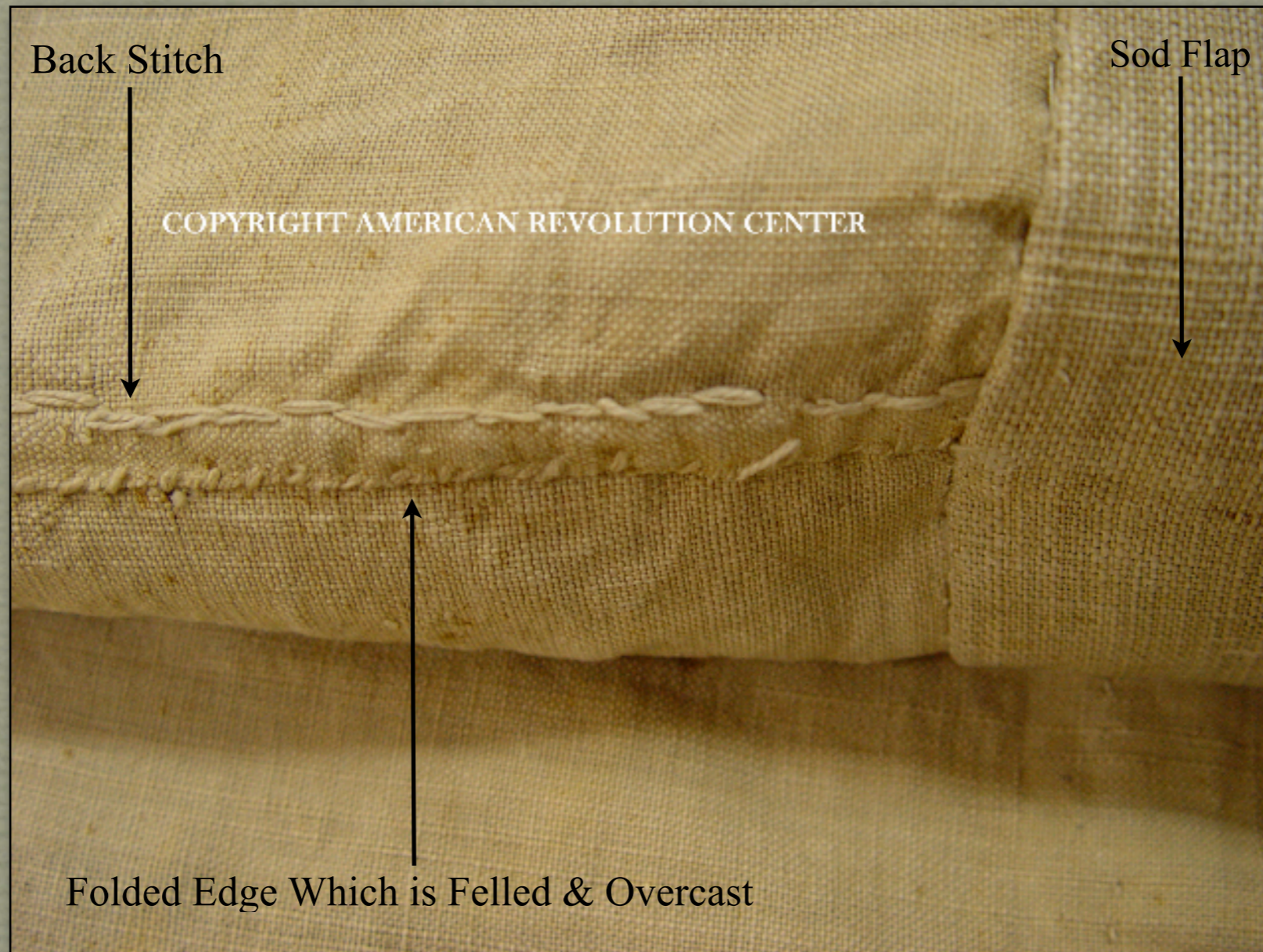

The Marquee of General George Washington - The American Revolution Center

Detail of backstitch construction of the Marquee of General George Washington. Note how sloppy this stitching is for the tent which sheltered the Commander in Chief of the Continental Army

TWINE AND NEEDLES:

As far as the materials utilized to actually sew sails (and therefore tents) together, David Steel's, "The Elements and Practice of Rigging And Seamanship," (1794) sheds light on some important basics:

"The TWINE for large sails, in the royal navy, is waxed by hand, with genuine bees-wax, mixed with one sixth part of clear turpentine; and, for small sails, in a mixture made with bees wax, 4 lb; hogs lard, 5 lb; and clear turpentine, 1 lb. In the merchant-service, the twine is dipped in tar, softened with a proper proportion of oil."

"TWINE is of two sorts, extra and ordinary; the extra is for seaming, and runs 360 fathoms to the pound; the ordinary is used to sew on the bolt-rope, and runs 200 fathoms to the pound. Twine for the navy is of three threads." (S-4, p. 90)

"It is the erroneous practice of some sail-makers not to sew the seams any farther than where the edge is creased down for the tabling; but all sails should be sewed quite home to the end, and, when finished, should be well rubbed down with a rubber."

"NEEDLES have three sides towards the point, and are of various sizes. They bear the following names, viz. large marline, small marline, double bolt-rope, large bolt-rope, small bolt-rope, store, old work, tabling, and flat-seam, needles- The needles should be no larger than is necessary to carry the twine, and the edges should be taken off, that the canvas may not be cut." (S-4, p. 88)

SECURING THE TENT TO THE EARTH: TENT LOOPS AND GROMMETS

During the 18th Century, an other ranks' tent was held in place by wooden "Pins" or "Pegs" attached to hemp "Cords" tied into "Loops". These loops were located within the base seam of the tent, and were usually positioned at the junction of each body seam.

"1780.

January 1st.

Portsmouth.

Major Genl: Baron Steuben to Col. Muter...

I must beg you to furnish Colo Davis with such articles as he may be in immediate necessity for & cannot otherwise procure - he is particularly in want of some chords to make loops for the tents he has & which without them are entirely useless-..." (P-1)

Orderly Book of Colonel and Brigadier General Samuel Elbert

"General Orders.

Head qrs., Savannah, the 19th Feby., 1778...

He [the Deputy Quarter Master General] will... provide a number of bags, a quantity of cords fit for tents, and the lines, ropes and cordage necessary for four battalions." (need bibliography p. 105)

Peg Loops were attached to a tent by passing through either one or two holes known as “Grommets”.

As we have seen before, we can gain some insight on the construction of these tent holes or grommets by comparing them to those used in the process of manufacturing sails. In David Steel’s, “The Elements and Practice of Rigging And Seamanship,” (1794) we see the following:

“Holes are made by an instrument called a pegging awl, or a stabber, and are fenced round by stitching the edge to a small grommet, made with log or other line; when finished, they should be well stretched or rounded up by a pricker or a marline-spike.”

Steel also reveals that: “Reef and head Holes of large sails have grommets of 12-thread line, worked round with 18 to 21 stitches; smaller sails have grommets of 9-thread line, with 16 to 18 stitches, or as many as shall cover the line, and smaller holes in proportion... The holes, for marling the clues of sails and the top-brims of topsails, have grommets of log-line, and should have from 9 to 11 stitches; twelve holes are worked in each cloth.”

According to the interpretation of one source, some tent grommets (or Slit Holes) may have been reinforced with leather:

S. Dorsey, Jr., to Council.

“E[lk] R[idge] Furnace Aug 20th 1776.

Gentlemen. I have at last got a Tent for a pattern which I think is by no means a suitable one for the Purpose, therefore I have sent one of my make with the patern received from Baltimore for your directions which to pattern after. If they are made with leather on the slit holes & turned Rings and double slit holes cannot be done compleat for less than Twenty Two shillings and six pence. They Lake to make one of the Linnen of that size twenty three yards and no more. I have Hands engaged to make two a day from this time. I have sent you likewise a sample of Tent poles which I will likewise engage to make if you will send me up your price for them. If I can afford to make them at it I will proceed on them immediately. As you will want some Arm Tents should be glad to know whether I shall make you any of them and how many. They will be quite different from the others, but will make them as cheap as possible. If the Tent I have sent down to you, should think it too small, I will make the rest larger; but my man says they are full as large as any the tents at England...” (M-1)



Tafel 10: Detail des Zeltes H 2; Burg Forchtenstein/Burgenland

Detail From Ruth Bleckwenn's Text: "Zelt und Lager im AltPrussichen Heer"

Detail of a tent grommet from the extant Other Ranks' tent located at Burg Forchtenstein. This is an interior view of the tent. Here you can see a grommet lined with either a thick cord or leather. It is located within a hemp webbing reinforcement crudely sewn to the base of the tent. This grommet is actually located adjacent to a body seam. This view reveals that this tent is actually lined with a fine linen printed with floral decorations.



The Marquee of General George Washington - The American Revolution Center

Here we see a linen thread grommet sewn within a hemp webbing reinforcement that extends around the base of the canopy of General George Washington's Marquee. Through a series of these grommets, tension ropes attached to wood washers would secure the tent to the earth.

In this view, we can see two stain marks left over from metal hooks and eyes used to hang the walls of the Marquee to the canopy. These were removed in the 1970s when the tent underwent professional preservation. While this is by no means a representation of an other ranks' tent during the American Revolution, it is a good representation of the techniques used for making grommets during the period. Note that the thread is double wide linen.



“Tent Bag” for the Marquee of General George Washington

Tent Bag constructed using the same techniques as those used in the fabrication of the Marquee itself, including multiple Rope Grommets and Seams

HEMP LOOP CONSTRUCTION:

Extant examples of 18th Century tents reveal there were two basic styles of hemp loops. Accordingly, the difference between these two styles dictated the positioning and number of grommets required to secure the loops to the tent itself.

The first style of tent loop can be seen in an examination of the tents located at Burg Forchtenstein. Although it is difficult to ascertain the exact configuration of the loops on the aforementioned other ranks' tent, we can clearly see the details of the loops located on an Officer's Marquee.

Each loop is composed of a single cord of rope which passes through a singular grommet. One end of the cord is tied into a knot to form the loop itself. The other end is tied into a knot that pulls against a concave wooden washer resting against the tent grommet. These wooden washers are actually located on the exterior of the marquee, but it is uncertain as to whether or not these may have been removed and replaced in the wrong position by a museum curator. It is far more logical that the washers would be located on the inside of the tent.

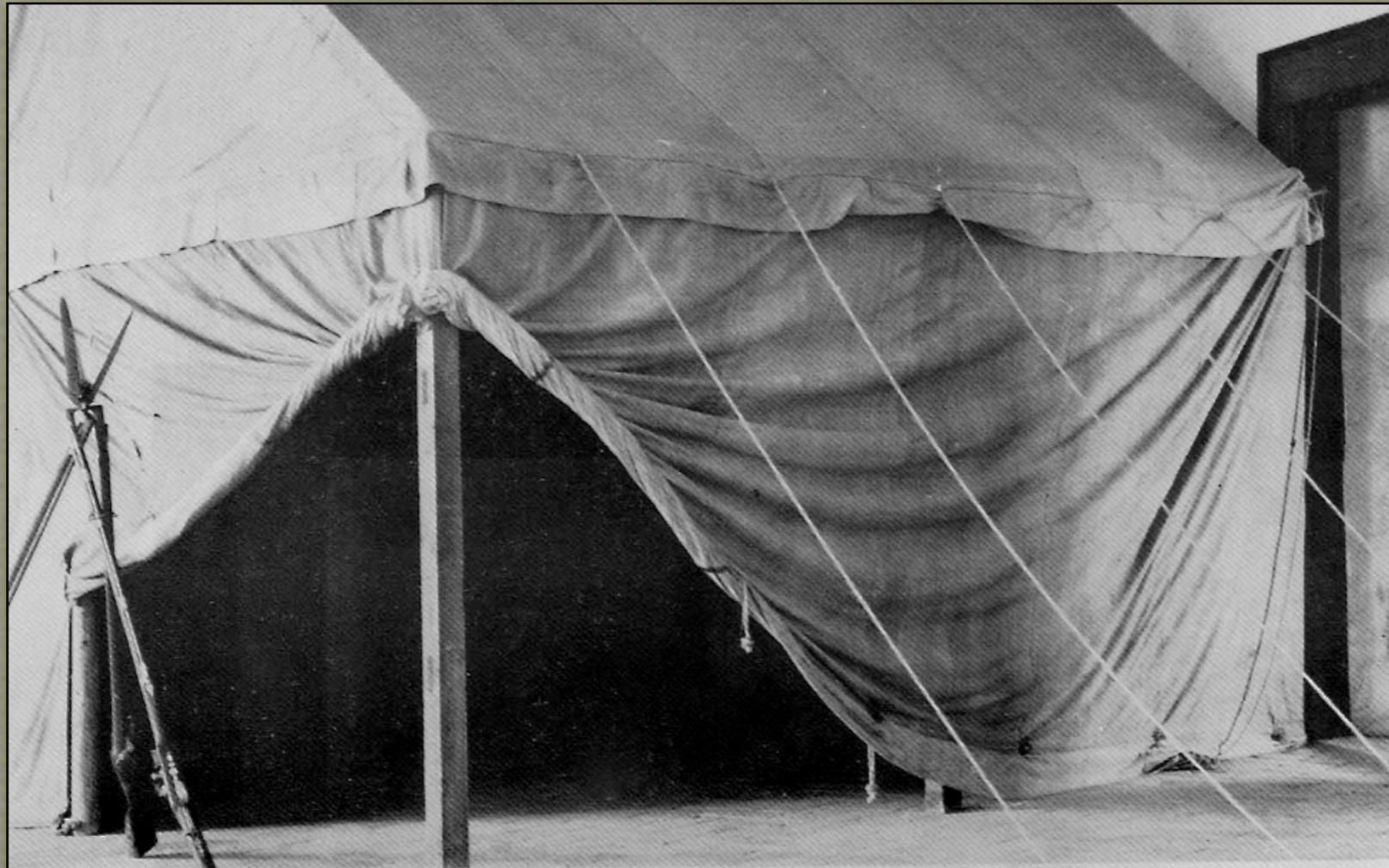

Tafel 8: Zelt eines höheren preußischen Offiziers aus dem 18. Jahrhundert,
Burg Forchtenstein/Burgenland, Schausammlung



Details From Ruth Bleckwenn's Text: "Zelt und Lager im AltPrussischen Heer"

During the 18th century, Marquee canopies were also secured with these combinations of cords and washers. They can be seen on the tent above, as well as the Marquee of General George Washington.



**American Revolution Center (ARC 2003.00.0868)
Washington Marquee Canopy Rope Tensioner**

“Bone” shaped hardwood (possibly oak) tensioner marked “5”
7 3/4” X 1/2” X 1 3/4”

Rope cord 188” long, 3-strand, 1/4” diameter in one section with knots tied at both ends.
One turned hardwood (possibly fruitwood) 1 1/4” diameter washer/disc at one end

This combination of loops with washers can also be seen on three unusual cords which extend out the sides of the other ranks' tent located at Burg Forchtenstein.

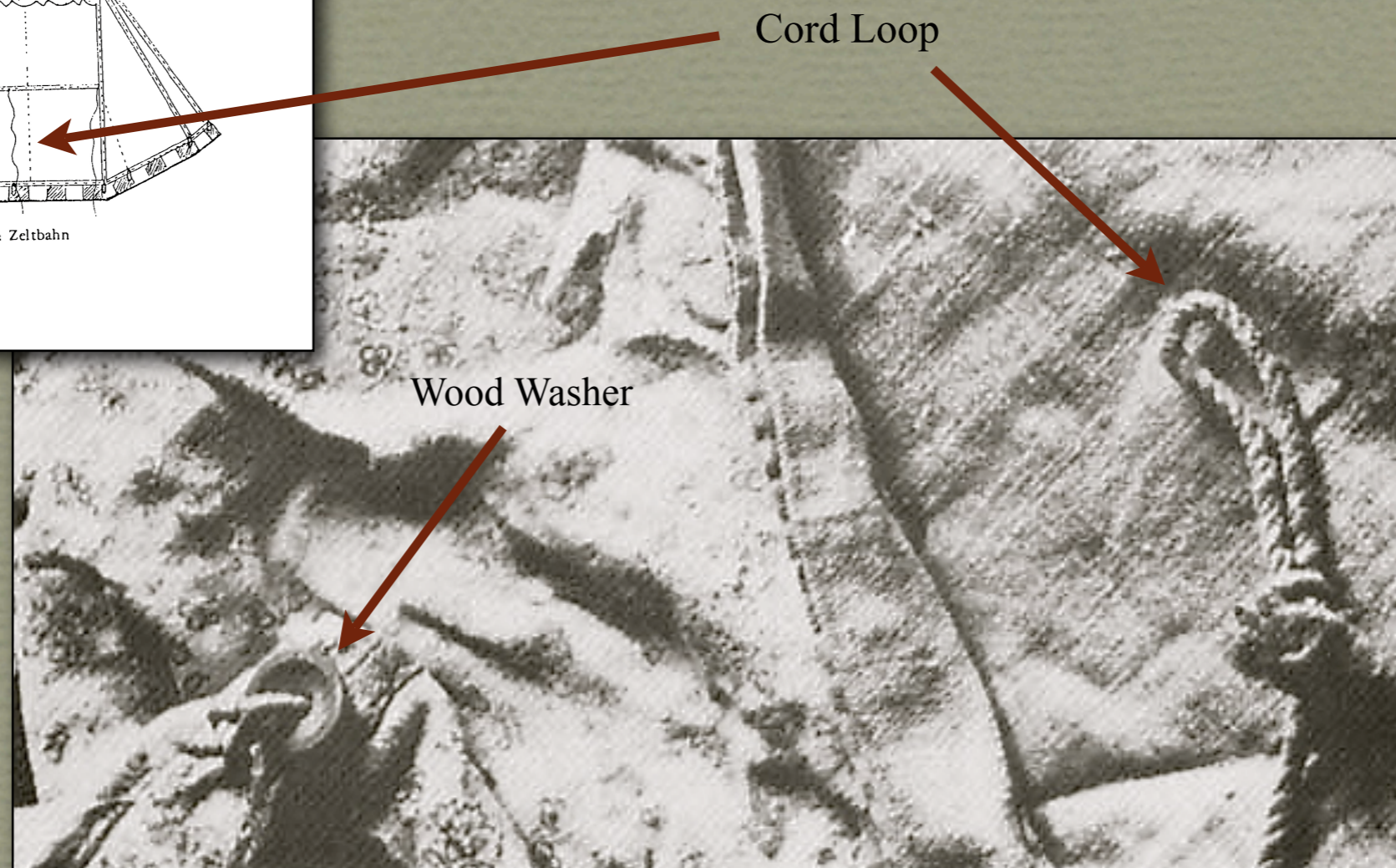
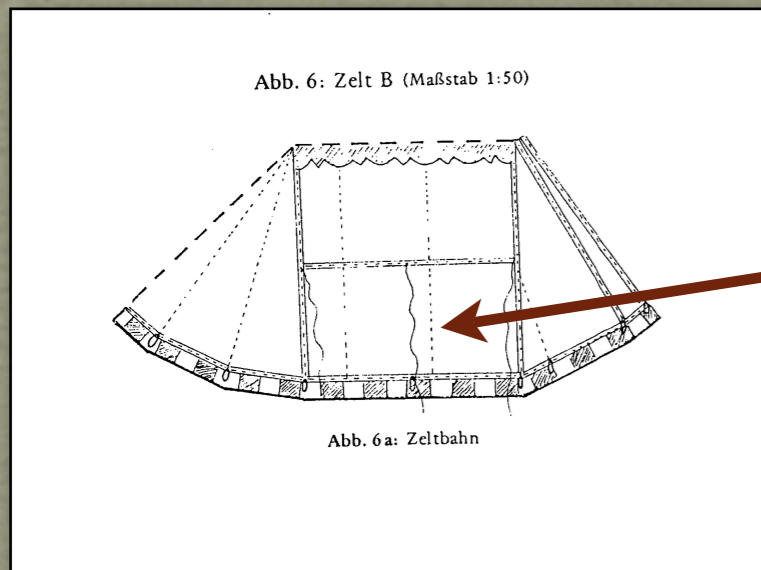

Detail From Ruth Bleckwenn's Text: "Zelt und Lager im AltPrussischen Heer"

Detail of the Other Ranks' Tent at Burg Forchtenstein revealing a hemp cord line looped at one end with a crude knot and secured at the other end by a knot which pulls against a concave wooden washer.

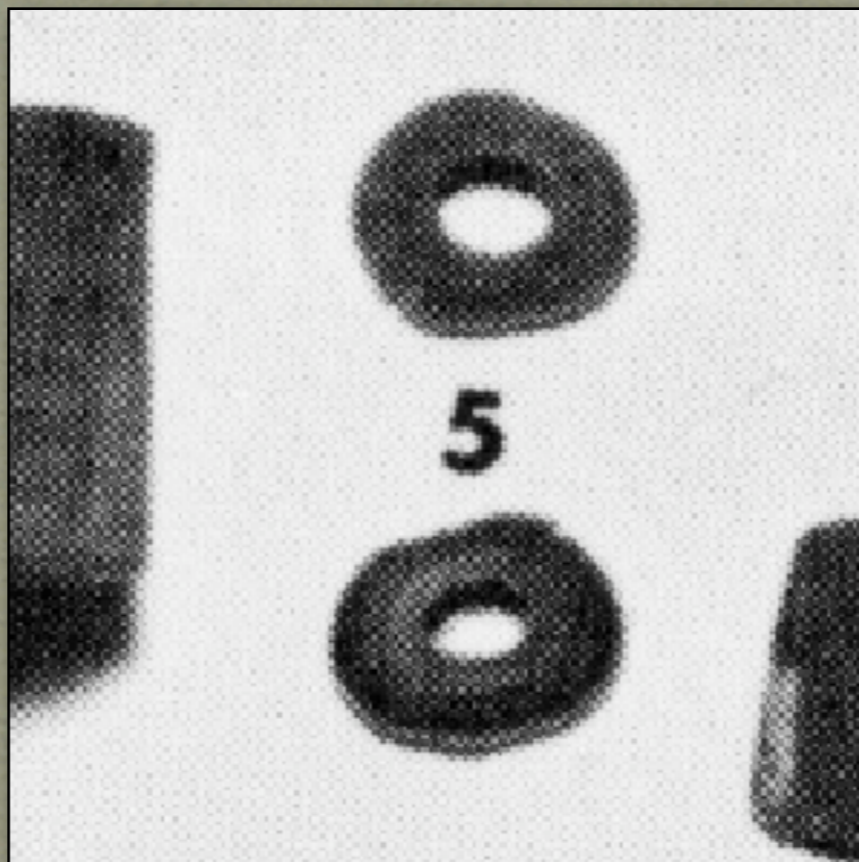

Detail of Wood Washers excavated at Fort Ligonier

Grimm, Jacob L., "Archaeological Investigation at Fort Ligonier, 1960-1965." Plate 28, No.5)

These wood rings have an outside diameter of 1.1" an inside diameter 0.4". They are 0.28" thick. One side is flat while the other side is convex. "The rings did not respond well to the preservatives and changed from circular to oval after removal from the stream." (G-2)

The use of washers can also be seen in writing. As previously cited above, we can see this in the following entry reviewing tent manufacturing:

S. Dorsey, Jr., to Council.

"E[lk] R[idge] Furnace Aug 20th 1776.

*... If they are made with leather on the slit holes & **turned Rings** and double slit holes cannot be done compleat for less than Twenty Two shillings and six pence" (M-1)*

The other means to attach a hemp loop to a tent can be seen in an examination of the Marquee of General George Washington. While this is certainly not an other ranks' tent, the techniques employed in its construction, in all likelihood, would probably have been quite similar. Here we see that the hemp loop was simply a single cord of hemp which passes through two grommets located adjacent to a seam. It was secured to the tent by two knots tied at either end.



Detail of the **Marquee of General George Washington** showing the positioning of two grommets located immediately adjacent to a side panel seam

TENT “PINS” OR “PEGS”

During the 18th Century, Tents were secured to the earth by wooden tent “PINS”, otherwise known as “PEGS.”

According to Lewis Lochee in 1778, an other ranks’ tent in the British Army was secured by 13 “pegs.”

Based on remaining specimens, tent pins ranged from 7 to 9 inches in length, had either a rounded or flat top, a notch to accept a cord loop, and a tapered body.

Excavations at Fort Ligonier revealed a total of 17 tent pins, or fragments of such pins, found within its ruins.

General George Washington’s Marquees still retains it’s original pins. They range from 7 to 9 inches in length.

Through period sources, we can define Tent Pins:

Charles James’ A New and Enlarged Military Dictionary (1805):

“Tent-pins; pieces of wood, which are indented at the top, and made sharp at the bottom, to keep the cords of a tent or marquee firm to the earth”

In certain circumstances, it has been found that soldiers found a way to make do when they were short on tent pins, much to the chagrin of their commanding officers:

Order Book of Colonel and Brigadier General Samuel Elbert

1st Pennsylvania Regiment

Headquarters, Fort Howe, 10th May, 1778

“The pinning down the borders of tents with bayonets seems to be too prevalent in camp, and to the utter astonishment of the Genl. he saw it yesterday at a tent which by the label, appeared to belong to an officer.” (D-2, pg. 139)



Tent Pin From the Marquee of General George Washington



BRITISH TENT PIN

British Tent Pin recovered from the British Sloop *Boscawen* which was constructed, and later sunk, on Lake Champlain off Fort Ticonderoga between the years 1767 - 1770. This fragment is made of a soft grained wood resembling Spruce. It is 0.635" thick and bears a 0.375" deep notch which is 0.625" long. (Fort Ticonderoga Collection)

TENT FLAPS AND CLOSURES

During the 18th century, the means to close the front opening of an other ranks' tent was simply to fasten the rope loops located along the base of each flap to a tent pin secured to the earth. These loops were located along the corners of each flap, as well as along the middle seam, or seams. The rope loops at the corner of each flap shared a common pin.

In the many period illustrations of British or Continental tents, there is absolutely **no evidence that flaps were closed by any other means. This includes ties.**

Examination of the extant enlisted man's tent now residing in the collection of Burg Forchtenstein confirms this observation. It is possible, however, that two sets of hooks and eyes MAY be present on this Prussian tent to assist in flap closure. Unfortunately, it is nearly impossible to make any definitive conclusion of this observation based upon the illustrations depicted in Bleckwenn's work.

Based on both contemporary illustrations of 18th century tents, as well as the characteristics of the extant Prussian tent, we can also determine that there were two basic means by which the flaps of a tent came together to form the opening.

In one manner, the front flaps simply met edge to edge from the base of the tent to its peak along the ridge pole. This method would entirely expose the end of the ridge pole when the flaps were pulled open.



London: Printed for Bowles & Carver,

52

A Perspective VIEW of an ENCAMPMENT.

No. 69, St. Pauls Church Yard.

GB-P1780 mf-2

**“A Perspective VIEW of an ENCAMPMENT”
Printed by Bowles and Carver**

Illustration revealing tent flaps which extend to the height of the ridge pole.



Colonel Thomas Musgrave, H.M. 40th Regiment of Foot, at Germantown

In this portrait of Colonel Thomas Musgrave, we see a portion of the camp of His Majesty's 40th Regiment of Foot. Note the presence of two Bells of Arms and four other ranks' tents. The front flaps of these tents extend to the height of the ridge poles. In the rear of this painting is Cliveden, home of Benjamin Chew, where a detachment of Battalion Company men of the 40th Foot held off a much larger division of Continental forces during the Battle of Germantown, Pennsylvania, on October 4, 1777.

In another manner of front flap design, the flaps of the tent appear to be connected and sewn together for the first 6" or so from the peak of the tent. This method would completely enclose the ridge pole when the flaps were pulled open. This method of construction would also create a slight overlap of the front flaps.



British Encampment Detail - Paul Sandby

In this view of a possible Quarter Guard of the British Army, we can see an other ranks' tent with a front flap opening which begins a short distance down from the peak of the ridge pole.



A Scene of the Camp on Hampden Green 1731

This view reveals two enlisted men placing tent pegs along the periphery of a wedge tent. Note that the pegs are also being placed through loops located along the front flaps which allows their closure. Loops were traditionally located at each panel seam. In this view, however, it appears that the loops were also located along the middle of each of the three side panels. Also of interest are the wooden mallets the soldiers are using in setting up their sleeping quarters. Note that the front flaps begin to open a short distance down from the top of the ridge pole, implying that they were sewn together for this short distance.



A Scene of the Camp on Hampden Green 1731

This view of a camp on Hampden Green dated 1731 shows a mess of men sleeping in their canvas quarters. Note that they sleep side to side. Their accoutrements and hats are laid out within an extension, or bell, at the rear of the tent. It is interesting to note that the flaps of the tent begin to open a short distance down from the peak of the ridge pole. When the flaps are open, the ridge pole would be completely covered.

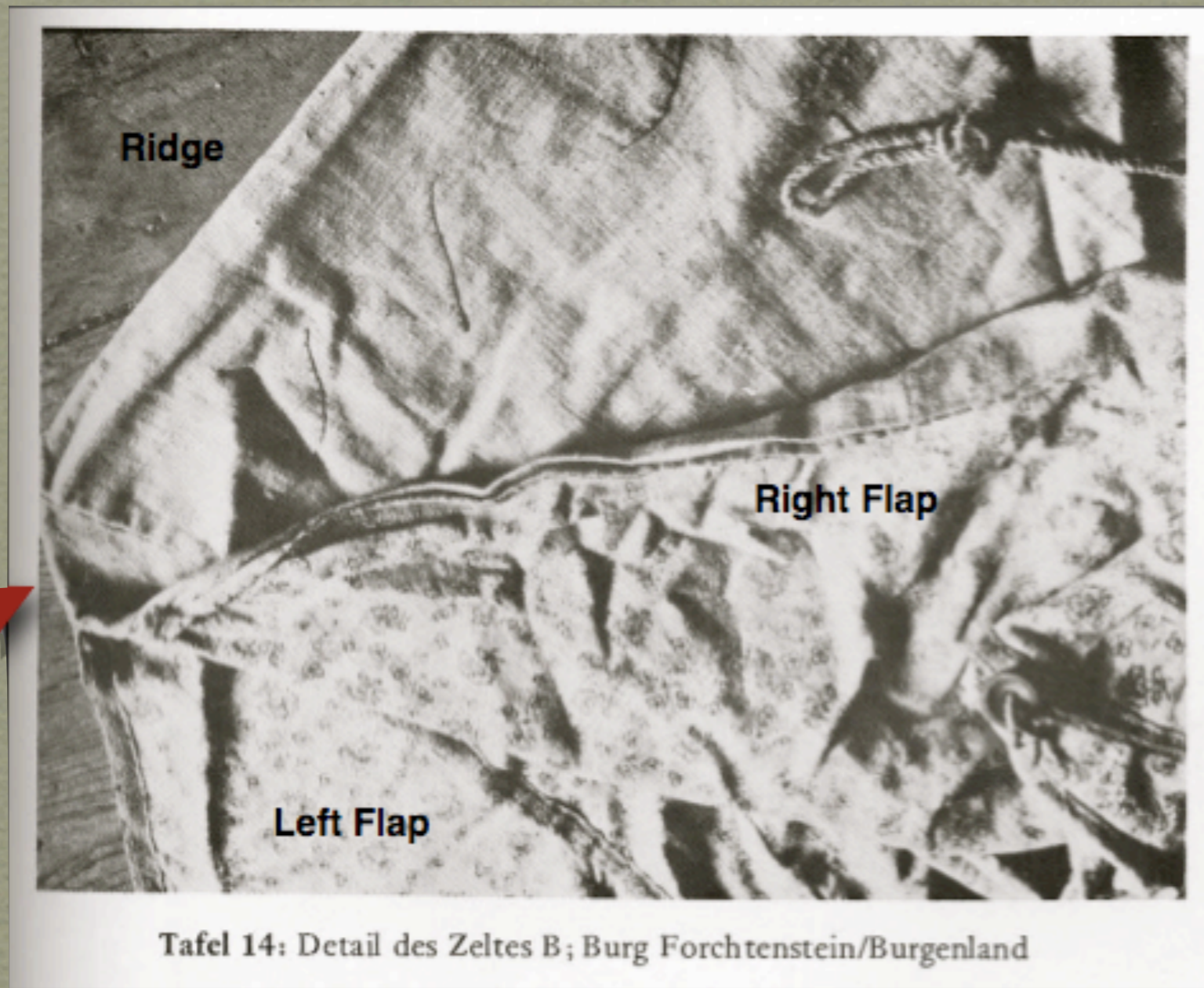

Detail From Ruth Bleckwenn's Text: "Zelt und Lager im AltPrussischen Heer"

This view shows the front flaps of a Prussian Enlisted Man's Tent which are sewn together for the first 6 inches or so down from the top of the ridge pole.

As far as the construction of the front flaps themselves, research reveals that they were composed of two or three triangular panels of cloth. This can be seen in both Lewis Lochee's illustration of a British other ranks' tent as well as the extant other ranks' tent in the collection of Burg Forchtenstein.

1 Seam
2 Panels

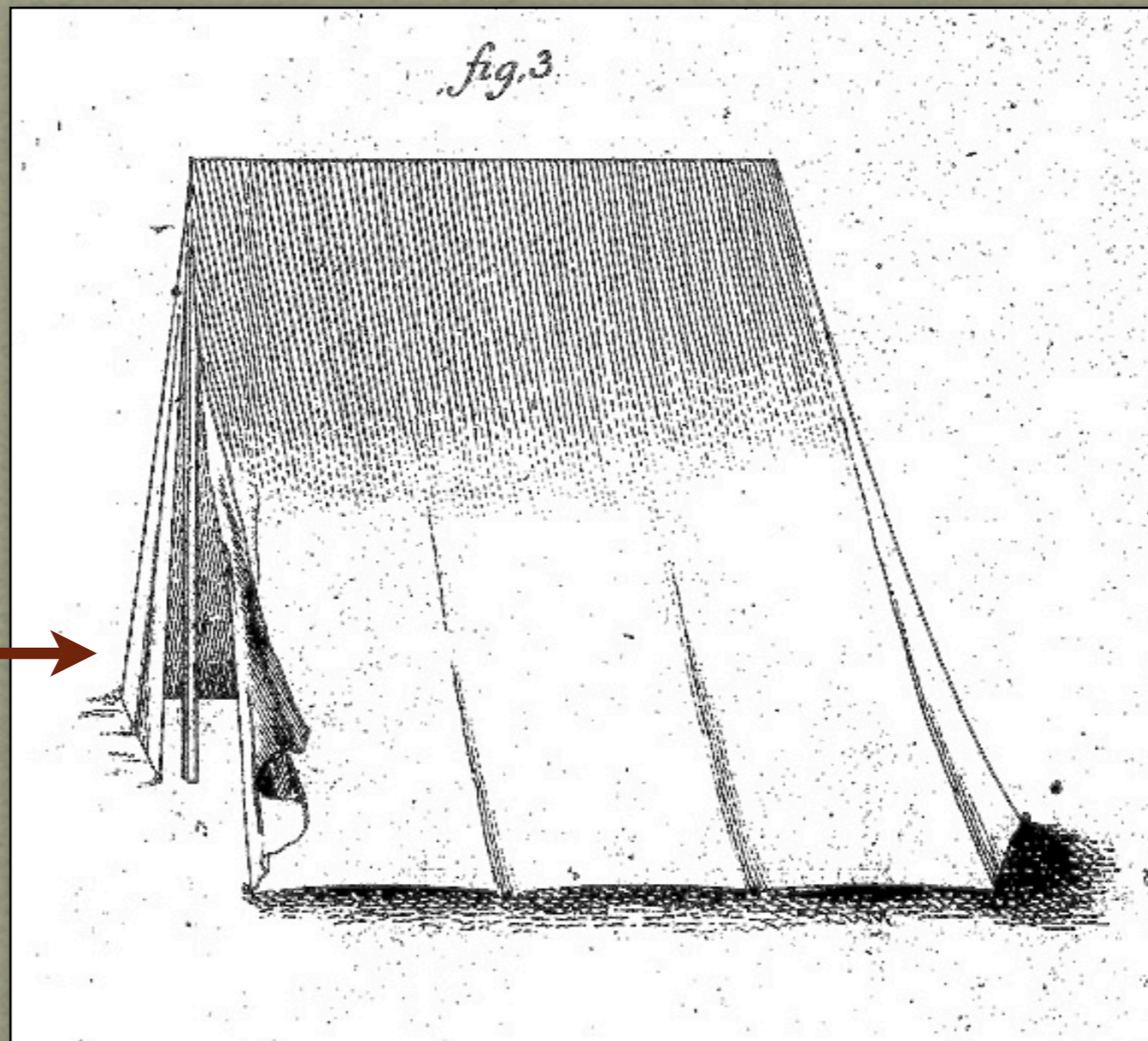
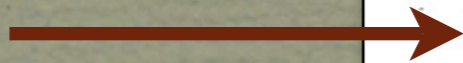

Detail from Lewis Lochee "An Essay On Castrametation" 1778

British Other Ranks' Tent

Revealing 3 Side Panel Construction, with 2 Panel Front Flaps, and a Bell Back

Abb. 6: Zelt B (Maßstab 1:50)

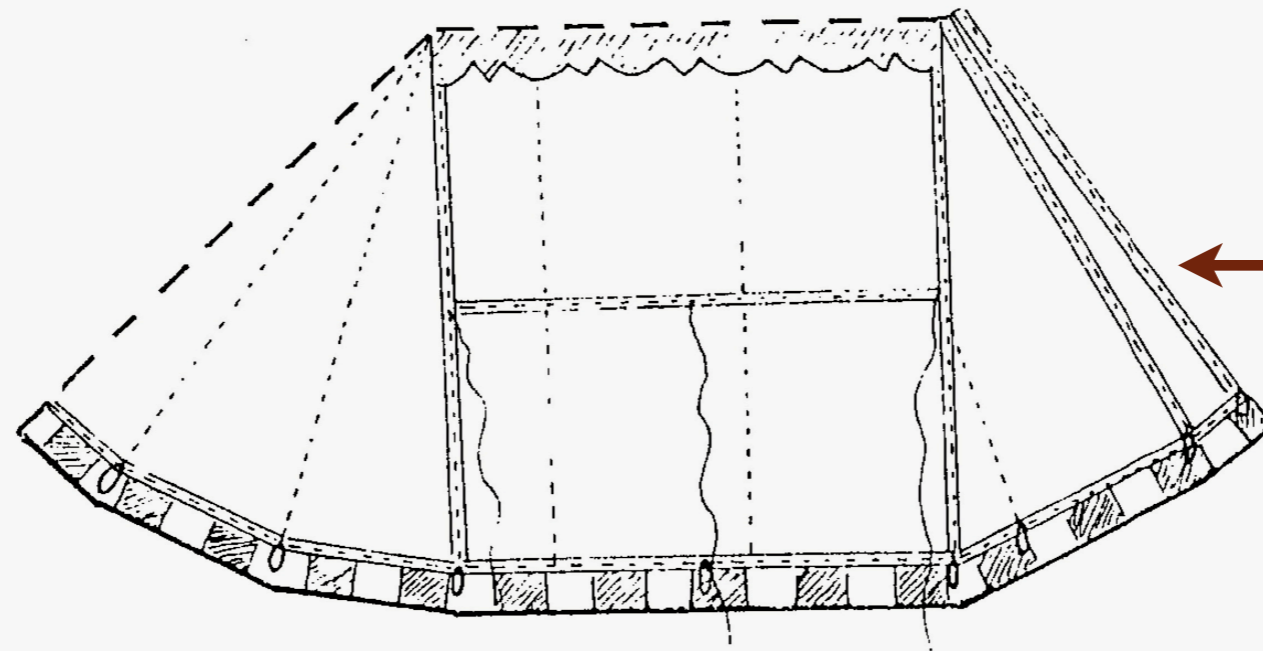

2 Seams
3 Panels

Abb. 6a: Zeltbahn

Detail From Ruth Bleckwenn's Text: "Zelt und Lager im AltPrussischen Heer"

TENT INTERIORS

The only evidence we have of the appearance of the inner aspect of an enlisted man's tent comes from the extant tent in the collection of Burg Forchtenstein in Austria. Whether or not this can be considered representative of the tents which saw service during the American War for Independence has yet to be determined.

Examination of this enlisted man's tent reveals some very interesting findings.

First, the entire interior has been lined with with a fine linen which has been printed with a floral pattern. The sides of the tent are made up of separate top and bottom panels. The front panel flaps and (presumably) the back wall of the tent are also lined with this material

Second, all of the seams of the interior panels, including the base of the tent, have been reinforced with a webbing material that appears to be between 3/4 to 1" in width. This material was (presumably) added to reinforce those areas which would be under greater strain due to the positioning of the grommet and tent loop configurations.

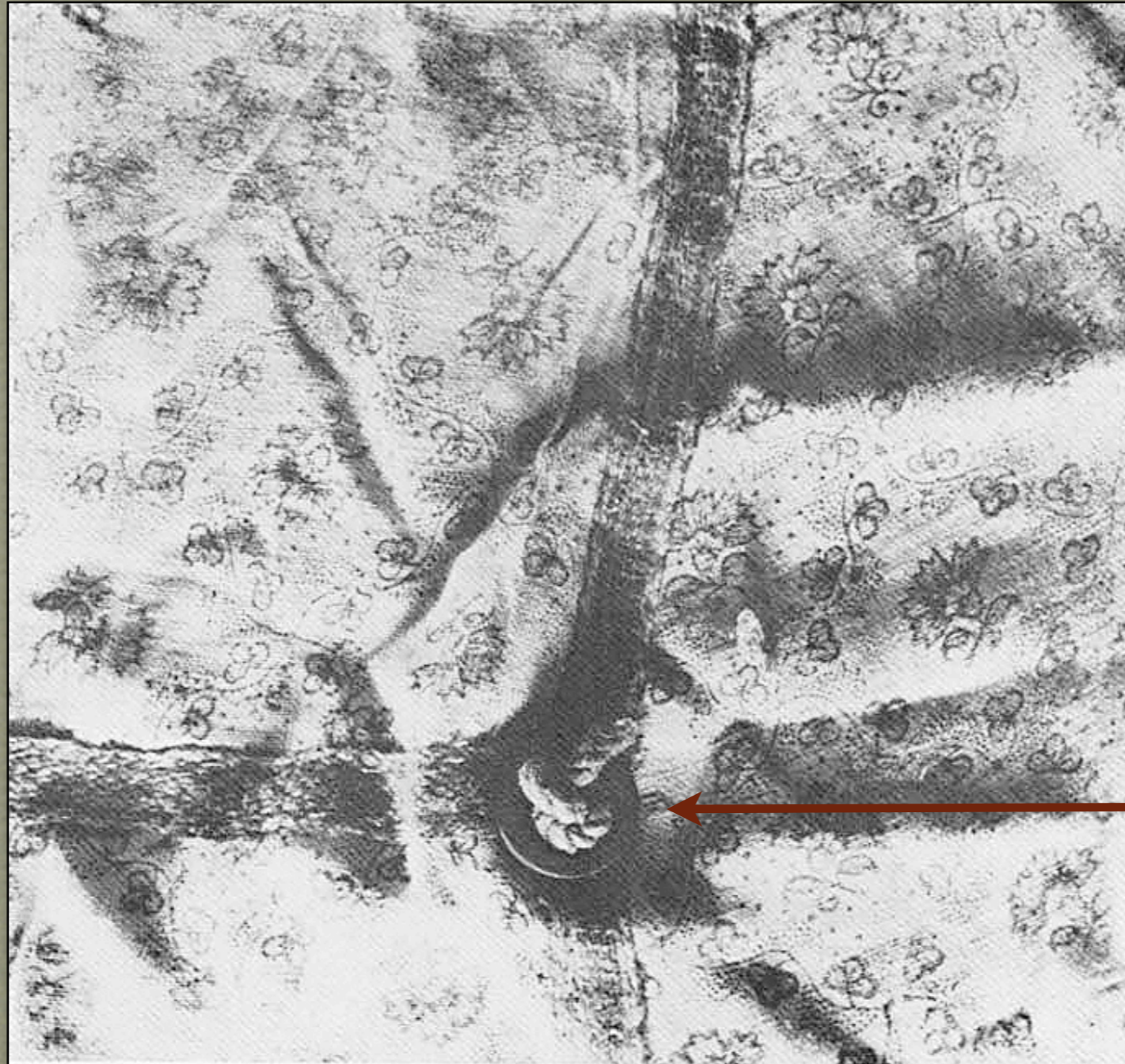

Wood Washer and Line
Extending out the Side
of the Tent. This is
NOT a Tent Loop

Tafel 15: Detail des Zeltes B; Burg Forchtenstein/Burgenland

Detail From Ruth Bleckwenn's Text: "Zelt und Lager im AltPrussischen Heer"

Detail revealing a hemp webbing sewn as a reinforcement over the interior seams

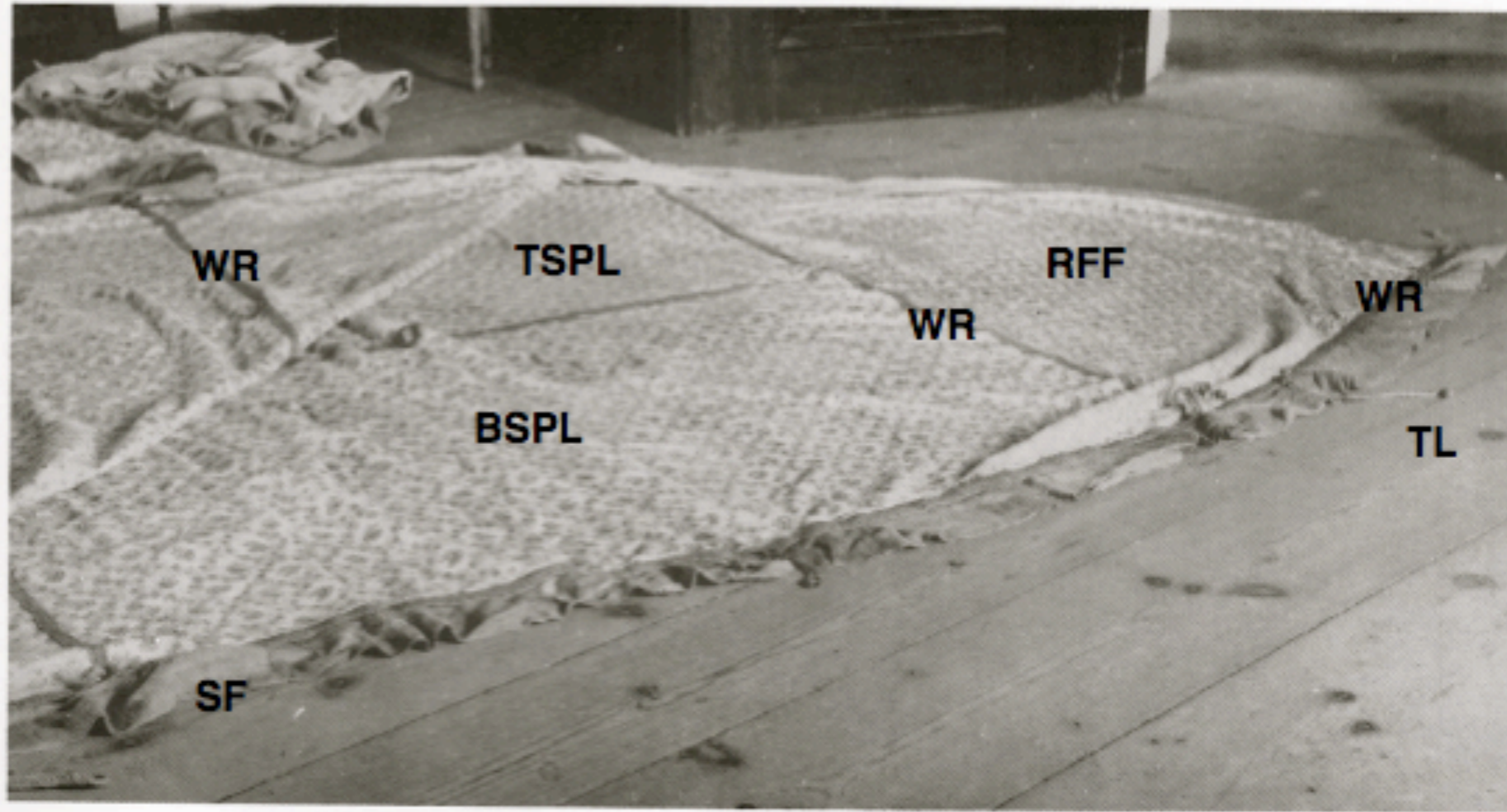

Tafel 17: Zelt B, ausgebreitet; Burg Forchtenstein/Burgenland

Detail From Ruth Bleckwenn's Text: "Zelt und Lager im AltPrussischen Heer"

In this view of the extant tent laid open, we can see the following:

- RFF** - Right Front Flap
- WR** - Webbing Reinforcement
- TSPL** - Top Side Panel Lining
- TL** - Tent Loop
- BSPL** - Bottom Side Panel Lining
- SF** - Sod Flap

SOD FLAPS

Examination of the other ranks' tent in the collection of Burg Forchtenstein, Austria, reveals the addition of external sod flaps along the base of the tent to aid in the reflection of mud and water. Based on black and white photographs as well as an artist's rendering, these flaps are highly decorated in an alternating pattern of dark and light panels.

Examination of the numerous illustrations of other ranks' tents for either the Continental or British forces serving in the American War for Independence reveals no such conclusive evidence that sod flaps were used. That being said, it is nearly impossible to rule out their use, particularly if they were located on the inside of the tent.

It is quite possible that the following reference is referring to sod flaps, albeit open to interpretation.

"Friday, August 4th, 1780...

Ordered, That so much of Mr. J. Bradford's letter, of July 12th, as relates to linen for tents and sod cloath, and sales of sugars, be referred to a committee of commerce..."

(C-2, p. 242)

We also have a "shopping list" put together by John Laurens in 1781:

Estimate of Clothing to be purchased in Holland by John Laurens for the American Army.

"1000 pieces of strong oznaburghs for the borders of tents - each piece to contain 100 yds. a 8d." (S-1)

Unfortunately, this entry is also wide open for interpretation. Could this be material for sod flaps, or simply a lining for the tents? Given the quantity of material requested (1000 pieces of 100 yard long material), could this be more of a webbing material? We just don't know.

What we do know is that the side panel walls of General George Washington's Marquee definitively shows the presence of sod flaps that are 22 cm wide.



The Marquee of General George Washington

Detail of General George Washington's Marquee showing the utilization of unbleached linen cloth for the sod flap.

SIDE WALL CONSTRUCTION

In general, other ranks' tents during the American Revolution were fabricated with three panels of cloth per side. For a seven foot tent, this would mean that each panel was roughly 28" wide, not including an allowance for seams.

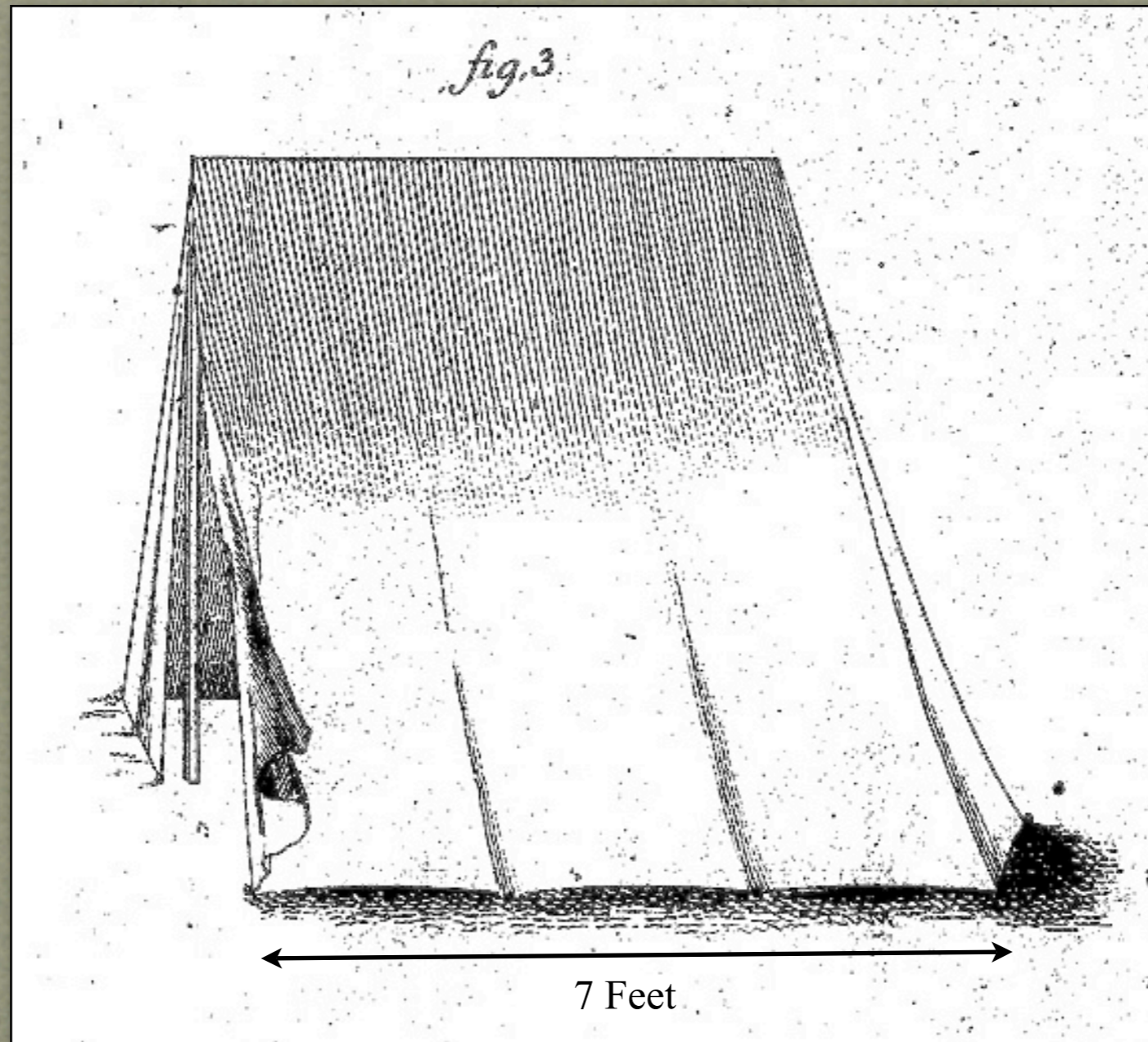

Detail from Lewis Lochee "An Essay On Castrametation" 1778

TENT BACK DESIGNS

During the American Revolution, there were three distinct designs to finish off the rear of an other ranks' tent.

“Bell” back tents incorporated an extension off the body of a tent to allow for the housing of a mess' accoutrements, kettle and hatchet. On the other hand, a “Flat” back tent had no such extension which made it a much smaller shelter.

Current research reveals that messmates actually slept side to side and perpendicular to the length of the tent itself. With this in mind, a “Bell” extension had many advantages over its counterpart.

The three designs of tent back construction which can be documented include:

1. The 3 Panel Bell Back Tent
2. The 6-7 Panel Bell Back Tent
3. The Flat Back Tent

The 3 Panel “Bell” Back Tent

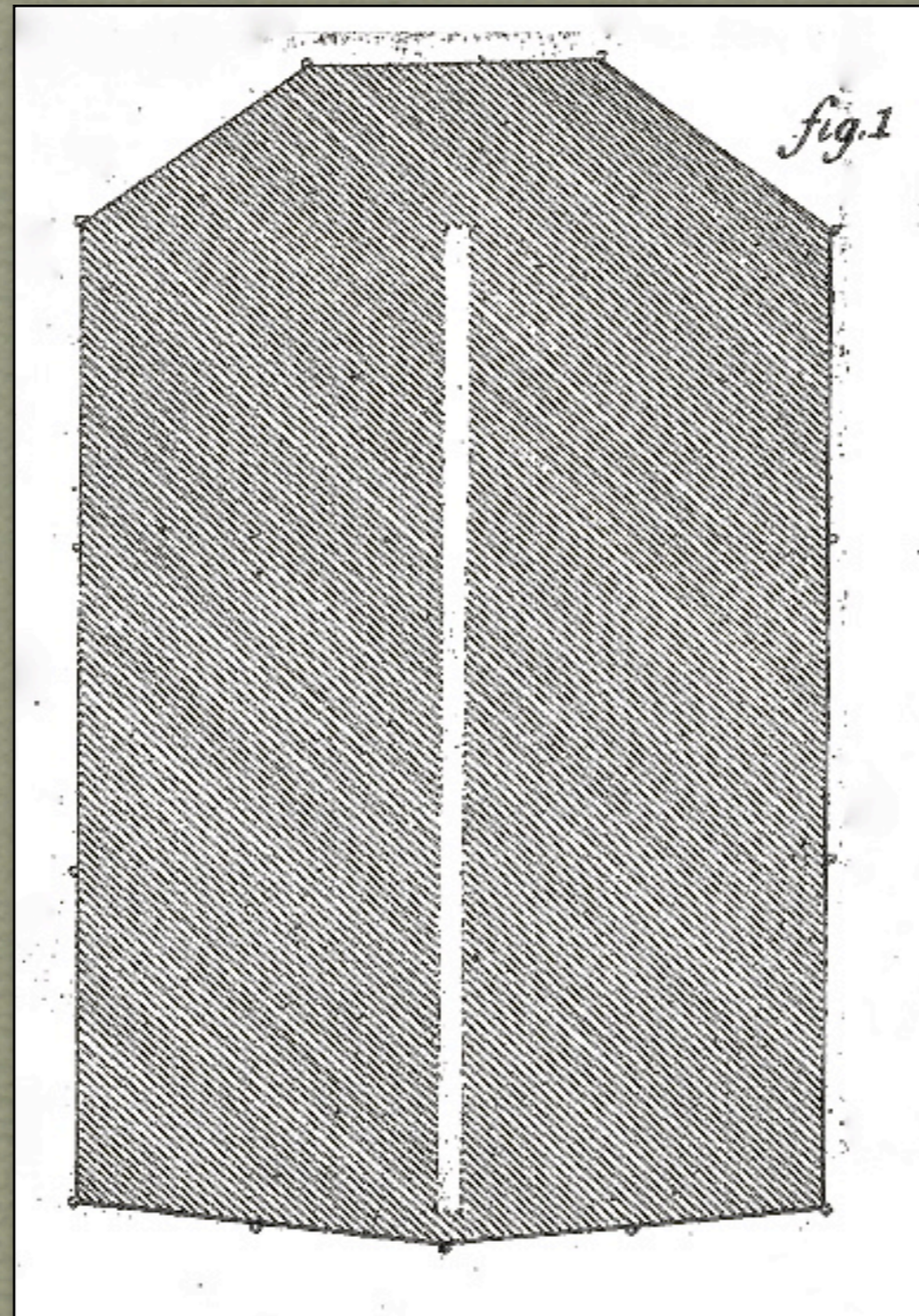

Detail from Lewis Lochee “An Essay On Castrametation” 1778

Three Panel British Bell Back Tent. Note the 13 loop locations, including those on the two front flaps which are closed by a single peg shared in the center

The 6-7 Panel “Bell” Back Tent

Abb. 6: Zelt B (Maßstab 1:50)

6 Panel “Bell” Back



Abb. 6 a: Zeltbahn

Detail From Ruth Bleckwenn's Text: "Zelt und Lager im AltPrussischen Heer"

The 6-7 Panel "Bell" Back Tent

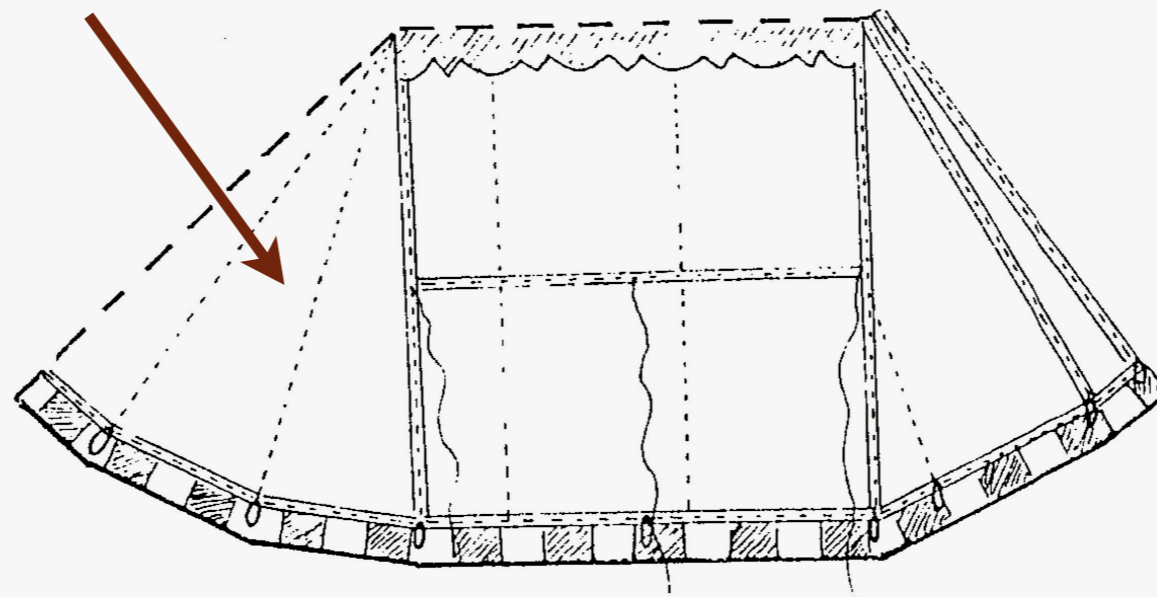
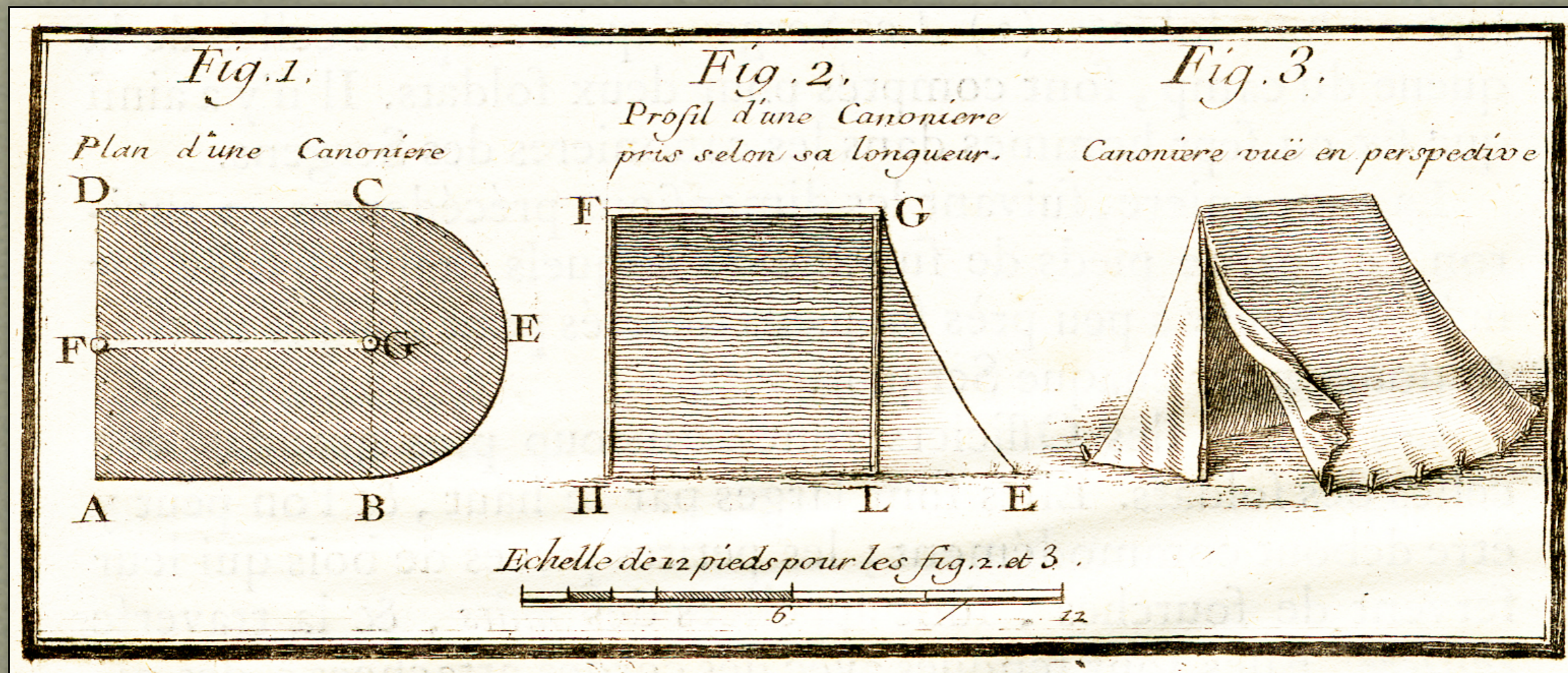

“Encyclopédie, Ou Dictionnaire Raisonné Des Sciences, Des Arts et Des Métier”

Denis Diderot

A depiction of a French Other Ranks' tent with a bell back extension as seen in Dennis Diderot's "Encyclopedia" c. 1751-1772

The 6-7 Panel “Bell” Back Tent

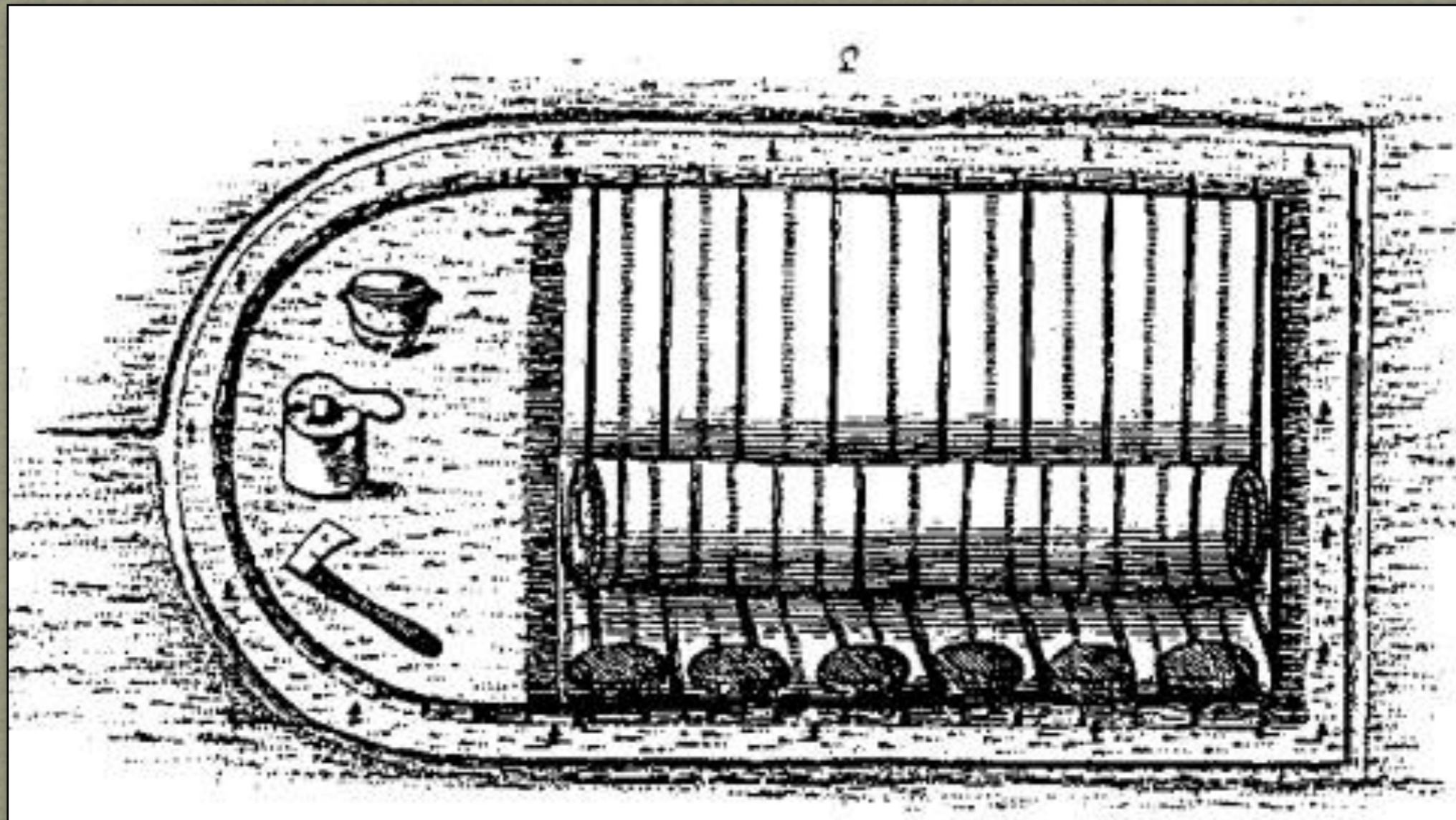

**“Was ist jedem Officier wahrend eines Fedzugs zu wissen nothig”
(What Every Officer Needs To Know During A Campaign”
1788**

German Officer Manual revealing a cut away 6 panel “Bell” Back extension. Note the trench dug around the periphery of the tent, as well as the mess kettle, tin water bottle (canteen), and mess hatchet.

The Flat Back Tent



Brigade of Guards Flat Back Tents
July 1, 1777

The Flat Back Tent



London: Printed for Bowles & Carver,
52

A Perspective VIEW of an ENCAMPMENT.

No. 69, St. Pauls Church Yard.

GB-P1780 MF-2

“A Perspective View Of An Encampment” by Bowles and Carver

This view of a British encampment reveals Other Ranks’ tents with a flat back design.

TENT POLES

1781

February 3d.

Chesterfield Co.

Col. Wm Davies to the Governor:

“It will be a great saving in the end to have tent poles made. Without them the tents will be ruined in a fortnight...” p. 488. (P-1)

Other ranks' tents during the American Revolution were held up by three tent poles. This included two upright, “Standard” Poles (traditionally 6 feet in height in the British Army) and one horizontal “Ridge” Pole (traditionally 7 feet in length in the British Army) that would rest upon the former and be held in place by two iron pins.

Lewis Lochee, *“Essay on Castremetation”*

1778

*“These tents are fixed by means of **three poles and thirteen pegs**: The poles A are called **Standard Poles**, and are about **6 feet high**; the pole B is called **Ridge Pole**, and is about **7 feet long**: The ridge and standard poles are held together by **two iron pins**, fixed in the top of the standard poles.”*

According to pictorial and archaeological evidence, the shape of the standard poles varied. Some resources show that they were round. Others show that they were square, or even slightly rectangular in shape. Although it is hard to determine their exact diameter, we know from extant tent ferrules (see below) that the diameter of the square or slightly rectangular standard poles varied between 1.5 to 2”. It is reasonable to believe that round standard poles were shaped by a draw knife. Extant round standard poles from the 18th century other ranks' tent in the collections of Burg Forchtenstein reveal that they are round and fairly crudely carved, but others may have been more refined.

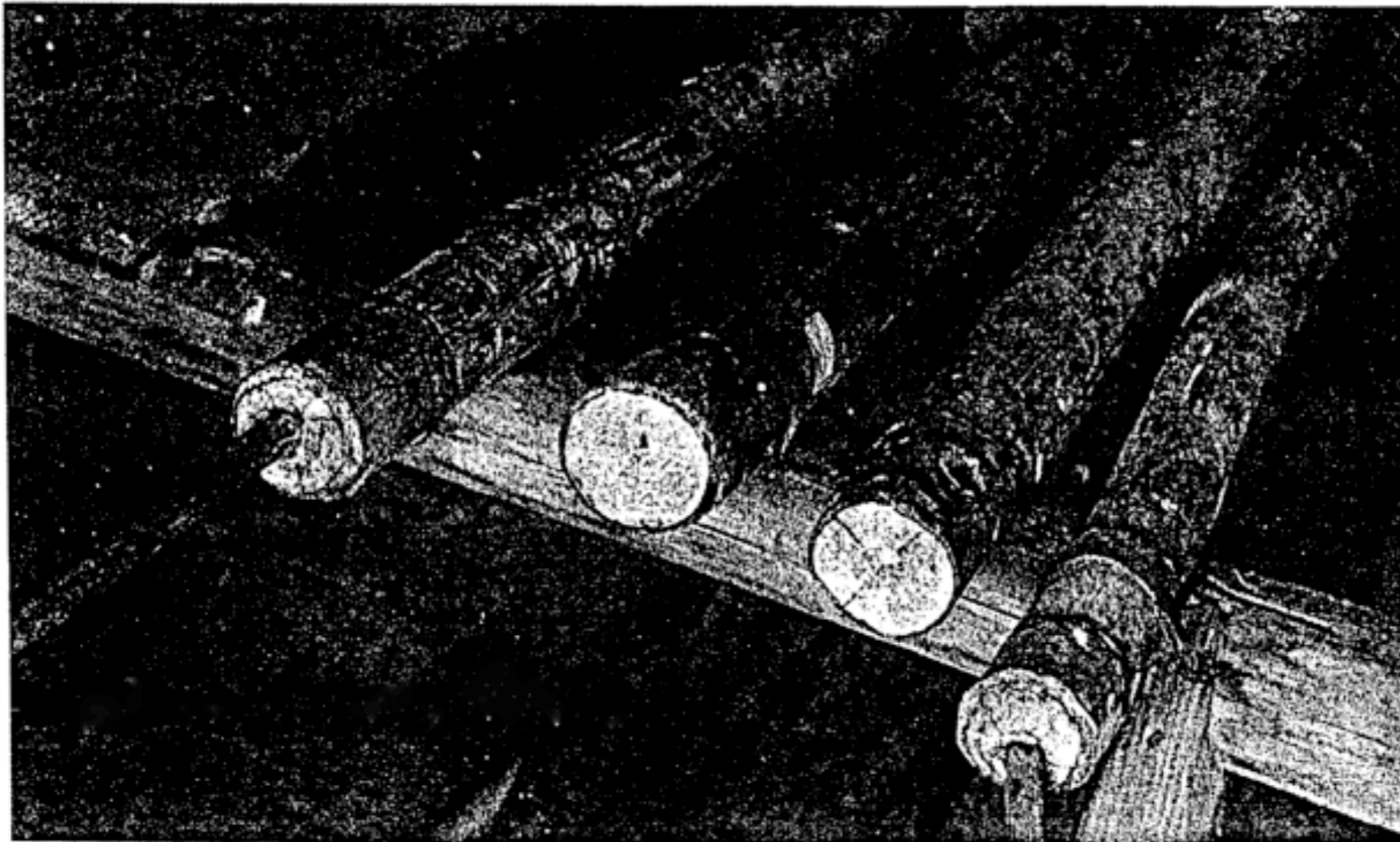

Tafel 41: Zeltstangen; Burg Fürchtenstein/Burgenland

Detail from Ruth Bleckwenn's Text: "Zelt und Lager im AltPrussischen Heer"

Extant round tent poles in Burg Forchtenstein



“The March of the Guard to Finchley” by William Hogarth

Round tent poles with iron pins can be seen in the transport wagon c. 1750



Extant Round Other Ranks' or Marquee Tent Pole Fragment - Fort Ticonderoga Collection

A remnant of a 2.0" diameter round standard tent pole of soft wood (possibly pine) which retains a 3.25" long iron pin and a 1.25" wide iron ferrule which has a 0.5" overlap

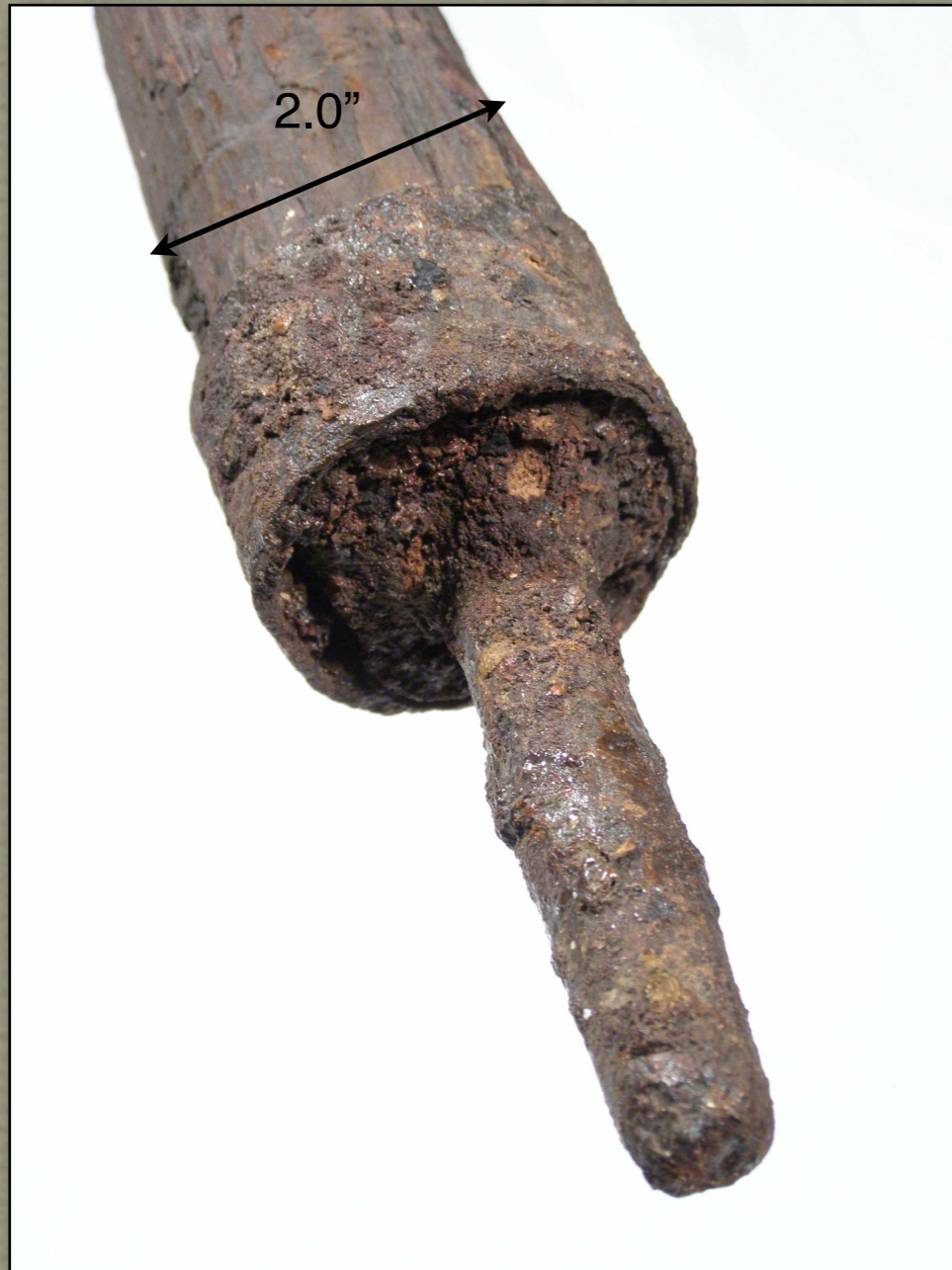

Extant Round Other Ranks' or Marquee Tent Pole Fragment - Fort Ticonderoga Collection

A remnant of a 2.0" diameter round standard tent pole of soft wood (possibly pine) which retains a 3.25" long iron pin and a 1.25" wide iron ferrule which has a 0.5" overlap

Quite frequently, Ridge Poles were shaped like the letter “D.” As previously mentioned, the flat portion of the Ridge Pole rested against the top ends of the two standard poles and was retained by iron pins. Based on the many illustrations of tents during the period, it is apparent that this pin did NOT extend through the ridge pole on either British or Continental tents. Pictorial evidence of French tents from the mid 18th century, however, reveal that this pin did extend through the ridge pole.

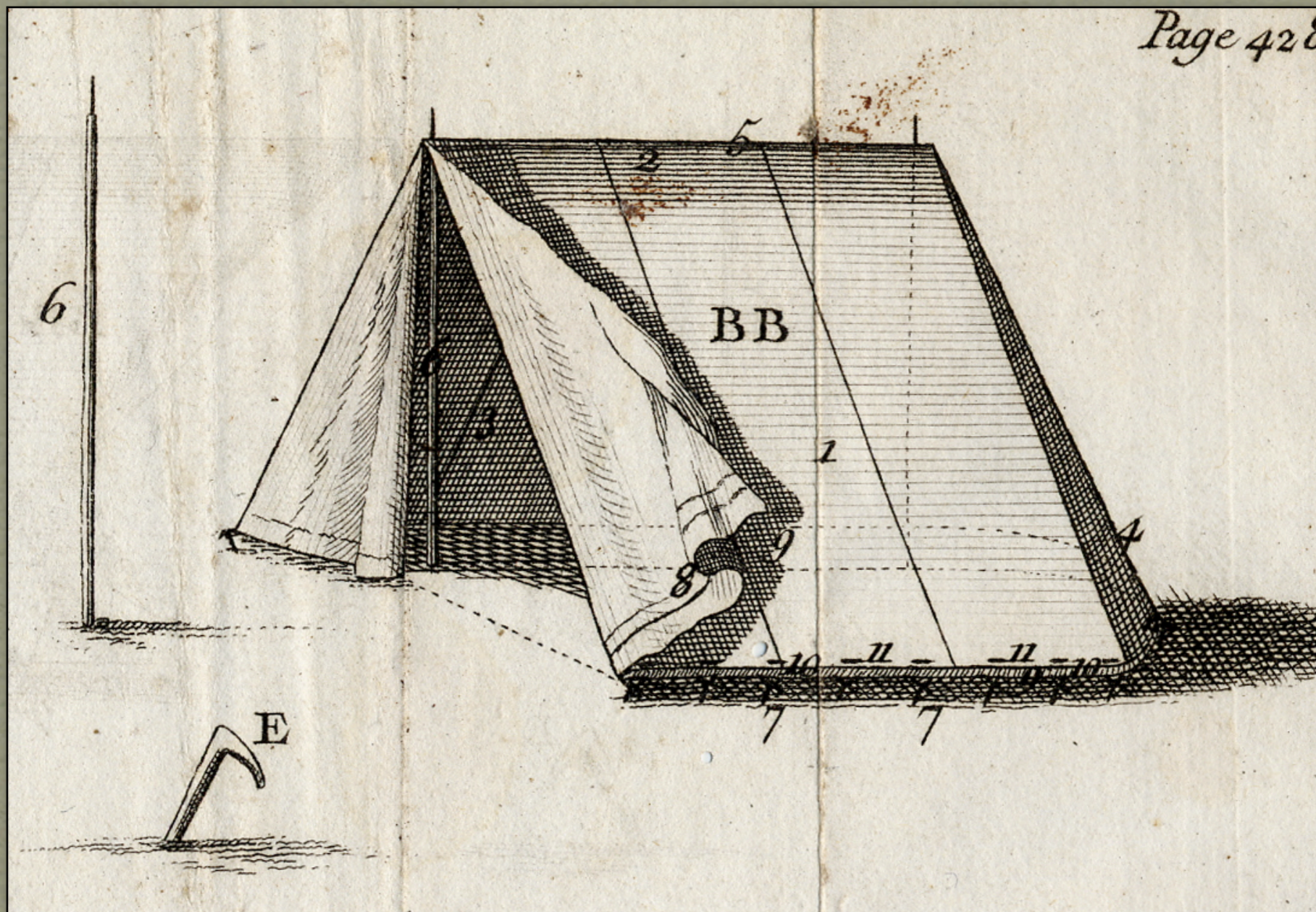

“Encyclopédie, Ou Dictionnaire Raisonné Des Sciences, Des Arts et Des Métier”

Denis Diderot

Tent poles during the time of the American Revolution were constructed out of wood. While there is very little written documentation regarding the TYPE of wood that was utilized, a 17th CENTURY English account for tents lists their accompanying poles being made out of “Firre” (Fir)

"3 Aprilis 1645

Tents for the Trayne 200 of John Snow Tentmaker the Tents viien foote long viien foote broad and six foote high of good Lockeram according to the pattern & wth firre staves lynes & pinns & other appurtenances according to ye best Trench Tents at xxs p Tent" (M-4)

As seen above, an extant other ranks' tent or marquee pole in the collection of Fort Ticonderoga is constructed out of a soft wood, possibly pine.

While there is evidence that some Marquee poles were painted, there is NO EVIDENCE that other ranks' tent poles were painted.

Order Book of Colonel and Brigadier General Samuel Elbert

“Headquarters, Fort Howe, 10th May, 1778...

The Genl. disapproves of the manner in which many of the men, pitch their tents, the heads of the poles are so sharp that they will soon force their way thro. the roofs. That this circumstance should escape the observation and correction of the officers of companies and quarter masters of regiments, is a matter of surprise to the Genl.” [??/p. 139.](#)

TENT POLE FERRULES

TENT POLE FERRULES were thin iron bands, or straps, which were wrapped around the end of a tent pole to prevent the wood in that region from splitting. They were often secured in place by a small iron nail. There are numerous examples of tent pole ferrules which have been excavated from archaeological sites of the American War for Independence. Many are square to slightly rectangular in shape. Given this, it is reasonable to assume that the poles to which these ferrules were fitted were also of the same dimension. Extant tent pole ferrules range in diameter from 1.5 to 2 inches. “D” shaped ferrules have also been excavated, giving evidence that ridge poles were also reinforced.

Below is an assortment of iron tent pole ferrules that have been excavated from various encampments sites that were located at Washington Heights, New York:



Tent Ferrules of the Encampments of Washington Heights

Tent Pole Ferrules have also been excavated from Forts Ligonier and Stanwix in Pennsylvania.

Jacob Grimm describes the Ferrules excavated at Fort Ligonier (dating from the period 1758-1766):

“Pl. 46. 3, 4.

Brackets recovered: 46, Studied: 42.

These are small oblong or square collars (like a box without top and bottom) made of iron band. (Plate 46, No. 4.). They were probably used as fasteners to bind joints between overlapping ends of two lengths of wood, possibly wagon parts. Lengths are from 1.2 inches to 1.8 inches, and widths from 0.8 inch to 1.5 inches. Lengths do not exceed widths more than 0.8 inch. The bands are from 0.4 inch to 0.6 inch wide and from 0.1 to 0.15 inch thick. Two large brackets, 1.6 inches by 4 inches, were recovered. These are 0.8 inch wide and 0.12 inch thick.

Twenty of the better preserved specimens have two nail holes on opposite sides and some had nails in place. Ten have nail holes on the short side, and 10 on the long side. Two brackets have one slightly convex side (Plate 46, No. 4).” Grimm, p. 53.

Three representative examples are shown:

Oblong-convex,

Oblong. This artifact has two small nails remaining on the long sides; they are driven slightly off-center.

Square.

Length: 1.2” to 1.8.”

Width: 0.8” to 1.5.””

Hanson and Hsu describe the ferrules at Fort Stanwix:

“Wrought iron ferrules were used to reinforce pieces of wood, especially ends, to prevent them from splitting. Also, they were used to keep wood or bone handles clinched tightly over the tangs of metal implements. They were all made from strips of metal cut to the desired length, bent to the desired shape and the ends welded together. The welds were skillfully done and on some specimens are very difficult to detect. Specimens identical to these types were found at Fort Ligonier (G-2).

Type 1. Rectangular.

Variety a. Large with rounded corners. Two specimens were found (fig. 76a). They are seven to eight times larger than the other ferrules. One fitted on a piece of wood approximately 2-1/4 by 3-3/8 inches and the other on one 2-1/4 by 4 inches. The smaller ferrule is 5/8 inch wide and 3/16 inch thick; the larger specimen is 1 inch wide and 1/8 inch thick.

Variety b. Small with no attachment holes. Two specimens were found. One is square and the other rectangular. The rectangular ferrule measures 1-1/4 inches long and 3/4 inch wide. The strap is 1/2 inch wide and 1/16 inch thick. The other is 1-3/8 inches square made from a strap 1/2 inch wide and 1/16 inch thick.

Variety c. Small with one attachment hole. Five specimens were found (fig. 76b). Four are square and one is rectangular. Three of the square ferrules measure 1-1/8 inches on a side, the other is 1-1/4 inches on a side. They are made from 3/8-inch-wide strips, 1/16 inch thick. Three still have nails up to 1/2 inch long through a hole bored in the center of one side. The rectangular specimen measures 3/4 by 1-1/4 inches and is made from a strip 1/2 inch wide and 1/16 inch thick. A nail hole is in the middle of one short side.

Type 3. Round.

Variety a. No attachment holes (fig. 76d). There is a wide range of diameters and widths for these 29 ferrules. The diameters range from 7/8 inch to 2-7/8 inches, width of the metal 3/8 to 1 inch and thickness of the metal 1/16 to 3/16 inch.

Variety b. One attachment hole. The three specimens range in diameter from 1-1/4 to 1-5/8 inches, width of strip 5/8 to 7/8 inch and thickness of strip 1/16 to 3/16 inch.

Variety c. Two attachment holes. Two specimens were found. One is 2-7/8 inches in diameter and the other is 1-1/2 inches. They are made from strips 3/4 inch wide and 1/16 inch thick. The holes are bored approximately 180 degrees from each other.”

In order for an army to be equipped with tent poles, the services of both the Regimental **Carpenters** and **Smyths** (presumably to fashion Ferrules and pole pins) were called upon.

Orderly Book of H.M. 40th Regiment of Foot

“Morning Garrison Orders 9th: May 1777 [Amboy, New Jersey.]

Are return to be given in Immediately to the Adj: of the day of the names of the Carpenters and Smyths in the several Corps in a Garrison they are to be Employ’d in making tent poles —”

ACKNOWLEDGEMENTS

The authors are indebted to the following individuals and organizations for their generous input and support. Without their professional knowledge and invaluable resources, this project, and the depth to which it has been achieved, would not have been possible.

John U. Rees

Chris Fox - The Museum at Fort Ticonderoga (www.fort-ticonderoga.org)

Scott Stephenson - The American Revolution Center (www.americanrevolutioncenter.org)

Joel Bohy

Gregory Sandor

Roy P. Najecki

Eric Schnitzer

Tim Terrell

With special appreciation to William Rose and Darrell A. Martin for their editing talents

BIBLIOGRAPHY

B-1

Bellamy, Daniel; "A New, Complete, and Universal English Dictionary; for the Improvement of of all Those who have not had the Benefit of a Learned Education." Fourth Edition. J. Fuller, London. 1764.

B-2

Bleckwenn, Ruth: "Zelt und Lager im AltPrussischen Heer." ("Tent and Camp in the Old Prussian Army. The Old Prussian Army Appearance and Essence 1713-1807"), 1975

B-3

The Brigade Dispatch:

- Volume XXI No. 2 (Summer 1990): "Markings on Tents (company and regimental markings on tents, from period sources)"
- Volume XXIII No. 2 (Spring 1992): "Notes on Tents (period accounts of making, transporting, and pitching tents; bedding; officers' tents)"
- Volume XXIX No. 3 (Autumn 1999) "Applying Tent Markings"
- Volume XXX No. 3 (Autumn 2000): "Material and Construction of 18th Century Soldiers' Tents"
- Volume XXXII No. 4 (Winter 2002): "Tent Pins"

C-1

Carlsruhe; “Was ist jedem Officier waehrend eines Feldzugs zu wissen noethig” (“What it is necessary for each officer to know during a campaign”), Mit zehen Kupferplatten (trans. "with ten copper plates"), 1788

C-2

Claypoole, David: “Journals of Congress, from January 1st, 1780, to January 1st, 1781.” Philadelphia. Not dated. [Google Book Search.]

C-3

Commons, John R., et. al. “A Documentary History of American Industrial Society. Volume II. Extracts from the journal of Col. Richard Henderson. MS. in the possession of the Wisconsin Historical Society, Draper Collection, CC, vol. i, 23ff.] Arthur H. Clark Company, Cleveland, Ohio. 1910. [Google Book Search.]

C-4

Coffin, Joshua, A. B. S. H. S.; “A Sketch of Newbury, Newburyport, and West Newbury, from 1625 to 1845.” Samuel G. Drake, Boston. 1845.-1

D-1

Danton, Graham: "The Theory and Practice of Seamanship." 11th Edition, Antony Rowe Ltd., Eastbourne, 1962

D-2

DeRenne, Wymberley Jones; "Order Book of Samuel Elbert, Colonel and Brigadier General in the Continental Army." In "Collections of the Georgia Historical Society." Vol. V. Part 2. The Morning News Print, Savannah, Georgia. 1902. [Google Book Search.]

D-3

Diderot, Denis: "Encyclopedie, Ou Dictionnaire Raisonne Des Sciences, Des Arts et Des Metier". 1751 - 1772

F-1

Falconer, William: "An Universal Dictionary of the Marine." 1780.

<http://southseas.nla.gov.au/refs/falc/title.html>

G-1

Greene, George Washington; "The Life of Nathanael Greene, Major-General in the Army of the Revolution." Houghton, Mifflin and Company, Riverside Press, Cambridge, Massachusetts. 1897.

G-2

Grimm, Jacob L., "Archaeological Investigation at Fort Ligonier, 1960-1965." Annals of Carnegie Museum, Vol. 42. Pittsburgh, PA, 1970.

H-1

Hanson, Lee, & Hsu, Dick Ping; "Casemates & Cannonballs: Archaeological Investigations at Fort Stanwix National Monument." U. S. Department of the Interior, National Park Service, Washington, 1975. p. 150-51

H-2

Hoadley, Charles J., LL.D., ed.; "The Public Records of the State of Connecticut, from October, 1776, to February, 1778, Inclusive, with the Journal of the Council of Safety from October 11, 1776 to May 6, 1778, Inclusive, and an Appendix." Case, Lockwood and Brainard Company, Hartford, Connecticut. 1894. [Google Book Search.]

H-3

Holabird, Bvt. Brig.-Gen. S. B.; "Army Clothing." In "Journal of the Military Service Institution of the United States." Volume II. By authority of the Executive Council, New York. 1881. [Google Book Search.]

H-4

Extracts from the journal of Col. Richard Henderson. MS. in the possession of the Wisconsin Historical Society, Draper Collection, CC, vol. i, 23ff.

K-1

Kellogg, Louise Phelps and Thwaites, Reuben Gold, Documentary history of Dunmore's war, 1774, State Historical Society of Wisconsin; 1905

L-1

Lochee, Lewis "An Essay on Castrametation" , 1778

L-2

"Transactions of the Society Instituted at London for the Encouragement of Arts, Manufactures, and Commerce; with the Premiums offered in the Year 1791." Volume IX. T. Spilsbury, London. 1791.

M-1

Journal and Correspondence of the Maryland Council of Safety, July 7: December 31, 1776. Volume 12,

M-2

Montgomery, "Textiles in America", 1984

M-3

"Proceedings of the Massachusetts Historical Society." Second Series. Vol. V. 1889 - 1890." Published by the Society, Boston, Massachusetts. 1890.

M-4

Mungeam, G.I. 'Contracts for the supply of equipment to the New Model Army in 1645', Journal of Arms and Armor Society, Vol. VI, no. 3, 1969, pp. 53 - 115.

P -1

Palmer, Wm. P., M.D.; "Calendar of Virginia State Papers and other Manuscripts, 1752 - 1781, Preserved in the Capitol at Richmond." Vol. I. R. P. Walker, Superintendent of Public Printing, Richmond. 1875. pg, 408

P-2

Pennant, Thomas; "A Tour in Scotland, and Voyage to the Hebrides, 1772. Simmons, Andrew, ed; John Monk, Chester, Part 1, 1774, Part 2, 1776. Birlinn Ltd., Edinburgh, 1998.

P-3

"The Pennsylvania Magazine of History and Biography." Vol. XXII. Publication Fund of the Historical Society of Pennsylvania. Philadelphia, Pennsylvania. 1898. [Google Book Search.]

"Head Quarters, Roxborough, August 4, 1777.

In the present marching state of the Army every encumbrance proves greatly prejudicial to the service, the multitude of women in particular, especially those who are pregnant or have children are a clog on every movement." p. 307.

Q-1

Quaife, Milo M.; "A Picture of the First United States Army: The Journal of Captain Samuel Newman." In: "The Wisconsin Magazine of History." Vol. II. 1918-1919. Publications of the State Historical Society of Wisconsin. 1919.

R-1

Rees, John U. "'We... got ourselves cleverly settled for the night... ' Soldiers' Shelter on Campaign During the War for Independence: Tents in the Armies of the Revolution, Part I'" *Military Collector & Historian*, vol. 49, no. 3 (Fall 1997)

R-2

Rolt, Richard: "A new dictionary of trade and commerce: compiled from the information of the most eminent merchants, and from the works of the best writers on commercial subjects, in all languages. By Mr. Rolt, with the assistance of several eminent merchants. The second edition, with the addition of a new and accurate set of maps of the world, ... by Mr. Bowen printed for G. Keith; S. Crowder, and H. Woodgate and S. Brooks, London: 1761

S-1

Salley, A. S., ed.; "The Mission of John Laurens to Europe in 1781." ; "The South Carolina Historical and Genealogical Magazine." Volume II. South Carolina Historical Society. Walker, Evans & Cogswell Co., Charleston, South Carolina. 1901. [Google Book Search.]

S-2

Sheffield, John, Lord; "Observations on the Commerce of the American States." New Edition. J. Debrett, London. 1784.

S-3

Stone, Edwin Martin; "The Invasion of Canada in 1775: including the Journal of Captain Simeon Thayer, describing the Perils and Sufferings of the Army under Colonel Benedict Arnold, in its March through the Wilderness to Quebec: with Notes and Appendix." Knowles, Anthony & Co. 1867.

S-4

Steel, David; "The Elements and Practice of Rigging and Seamanship", 1794

S-5

Smith, Captain George; "An Universal Military Dictionary", London, 1779

T-1

Thwaites, Reuben Gold, LL.D., and Kellogg, Louise Phelps, Ph.D.; Documentary History of Dunmore's War 1774. Compiled from the Draper Manuscripts in the Library of the Wisconsin Historical Society and published at the charge of the Wisconsin Society of the Sons of the American Revolution." Wisconsin Historical Society, Madison, 1905.

W-1

Miscellaneous Numbered Records (The Manuscript File) in the War Department Collection of Revolutionary War Records 1775-1790s, no. 31492, 1971, (National Archives Microfilm Publication M859, reel 111), U.S. War Department Collection of Revolutionary War Records, Record Group 93, NA (hereafter cited as Pickering to Hatch (two letters, same date), 12 July 1781, Numbered Record Books, NA, vol. 127, reel 26, 134-136, 252-253.d

W-2

George Washington Papers at the Library of Congress, 1741-1799: Series 4.
General Correspondence. 1697-1799 Clement Biddle,
January 10, 1778, Cargo List of the Symetry (Brigantine)

W-3

Records of the Public Store in Williamsburg, 1775 - 1780, Virginia Public Library

Y-1

Young, Arthur; "A Six Months Tour through the North of England." 4 Vols. London, W. Strachan et al., 1771. Facsimile reprint, Augustus M. Kelley, NY, 1967

