

18th Century Material Culture
Tools
Miscellaneous

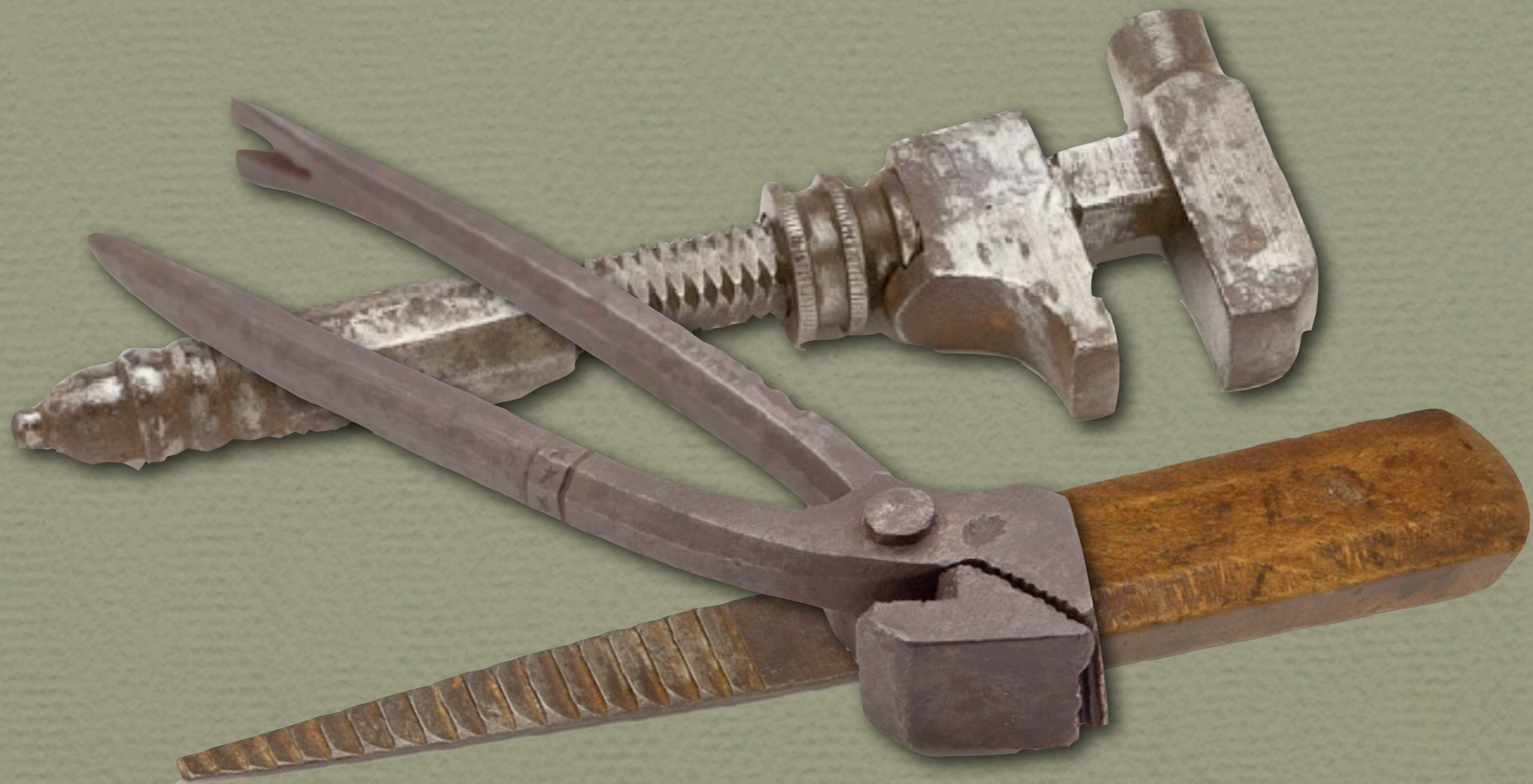

Files

2.7.8.4. FILES / PILNIKI

W-32/235/95, CMM/BO/1801

Site location / Lokalizacja: 22L3

Dimensions / Wymiary: length / długość 295 mm,
width / szerokość 30 mm.

Semicircular metal rod, its surface covered with a regular network of teeth, set in a wooden, cylindrical handle. Dimensions of metal part: length 80 mm, width 30 mm, thickness 5 mm. The wooden handle (length 115 mm, diameter 30 mm) is rounded at one end, and retains part of a reinforcing ring at the other end. The metal part of the file is badly corroded.

Półokrągły pręt z regularnymi ząbkami roboczymi na całej powierzchni metalowej, osadzony w drewnianej walcowatej rękojeści. Wymiary części metalowej: długość 80 mm, szerokość 30 mm, grubość 5 mm. Trzonek rękojeści drewniany o długości 115 mm i średnicy 30 mm, zaokrąglony z jednego końca, z fragmentem pierścienia wzmacniającego na drugim końcu. Część metalowa pilnika mocno skorodowana.

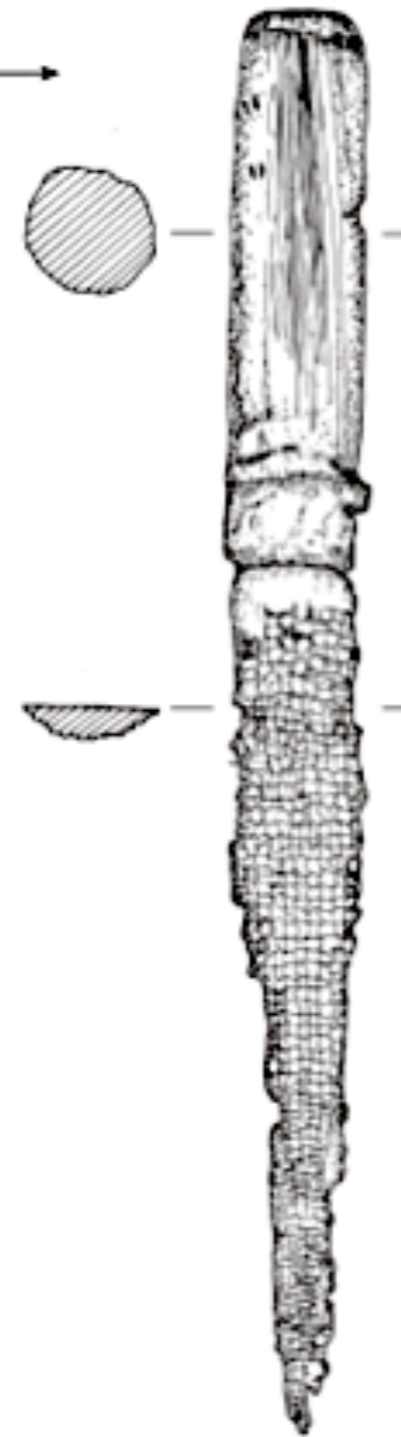

File. Recovered from the Wreck of the General Carleton of Whitby 1785

From: Ossowski, Waldemar, ed.; "The General Carleton Shipwreck, 1785."

Archaeological Research of the Polish Maritime Museum. Vol. I. Maritime Museum in Gdansk. Gdansk, Poland. 2008



English Rasp or File
Late 18th Century
(Colonial Williamsburg)



Left to Right: Triangular File Fragments, a Punch, Four Drill Bits - One bent into a Hook, Three Splitting Feathers, Two Knives and a Complete Half-round File with the Maker's Mark "IK"

c. 1705 - 1760

(Ephraim Sprague House Archaeological Site, Lebanon, Connecticut)

Floats



11" Plane Maker's Float
18th Century
(Jim Bode Tools)

Engraving Tools



Scrapers
18th Century
(Jim Bode Antique Tools)



Gouge
18th Century
(Jim Bode Antique Tools)

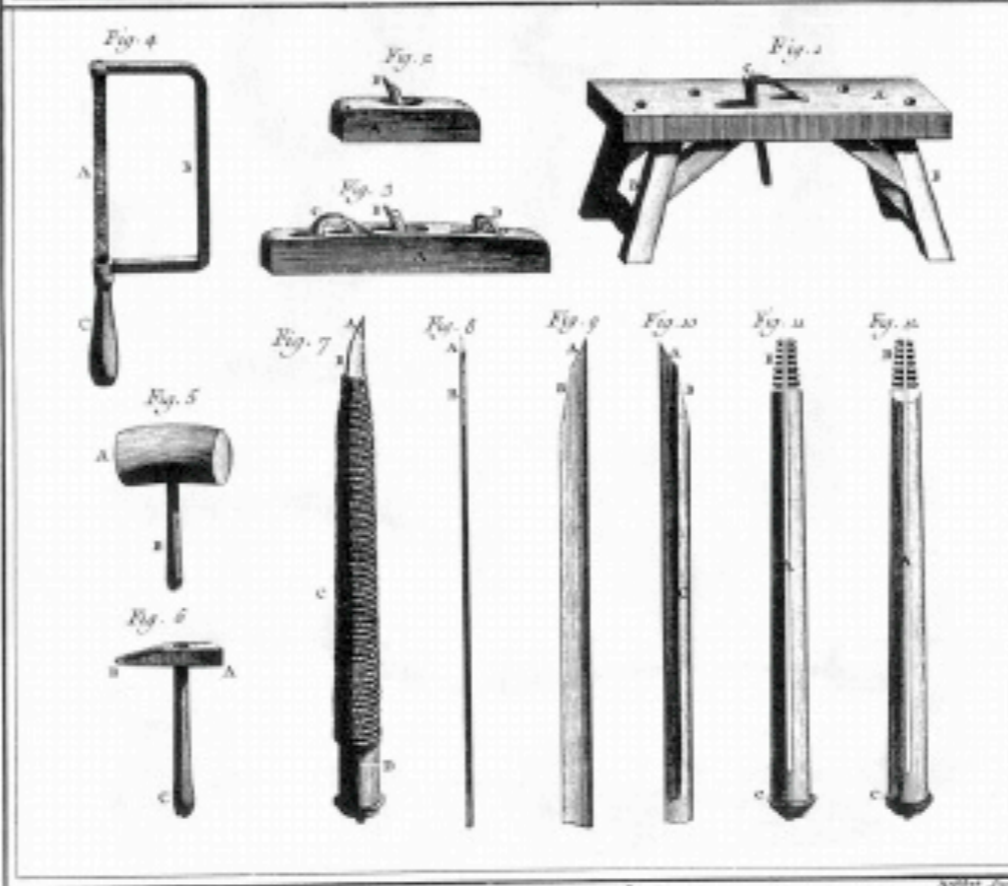
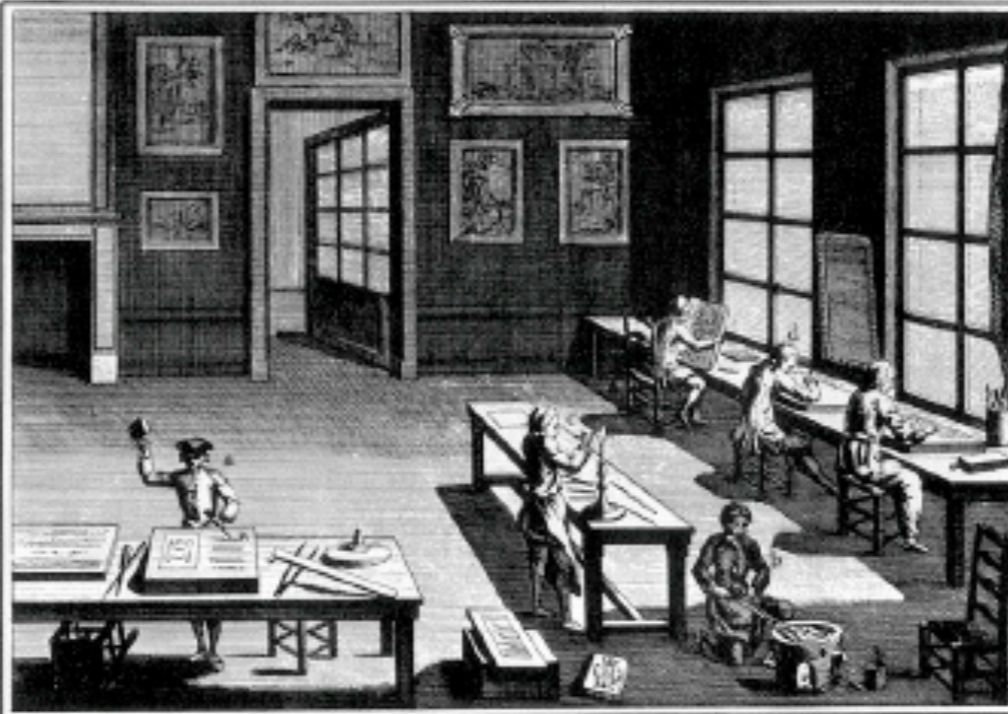

Gravure en Bois, Outils.

“Gravure en Bois”
 The Encyclopedia of Diderot & d'Alembert 1763
 (University of Michigan Library)

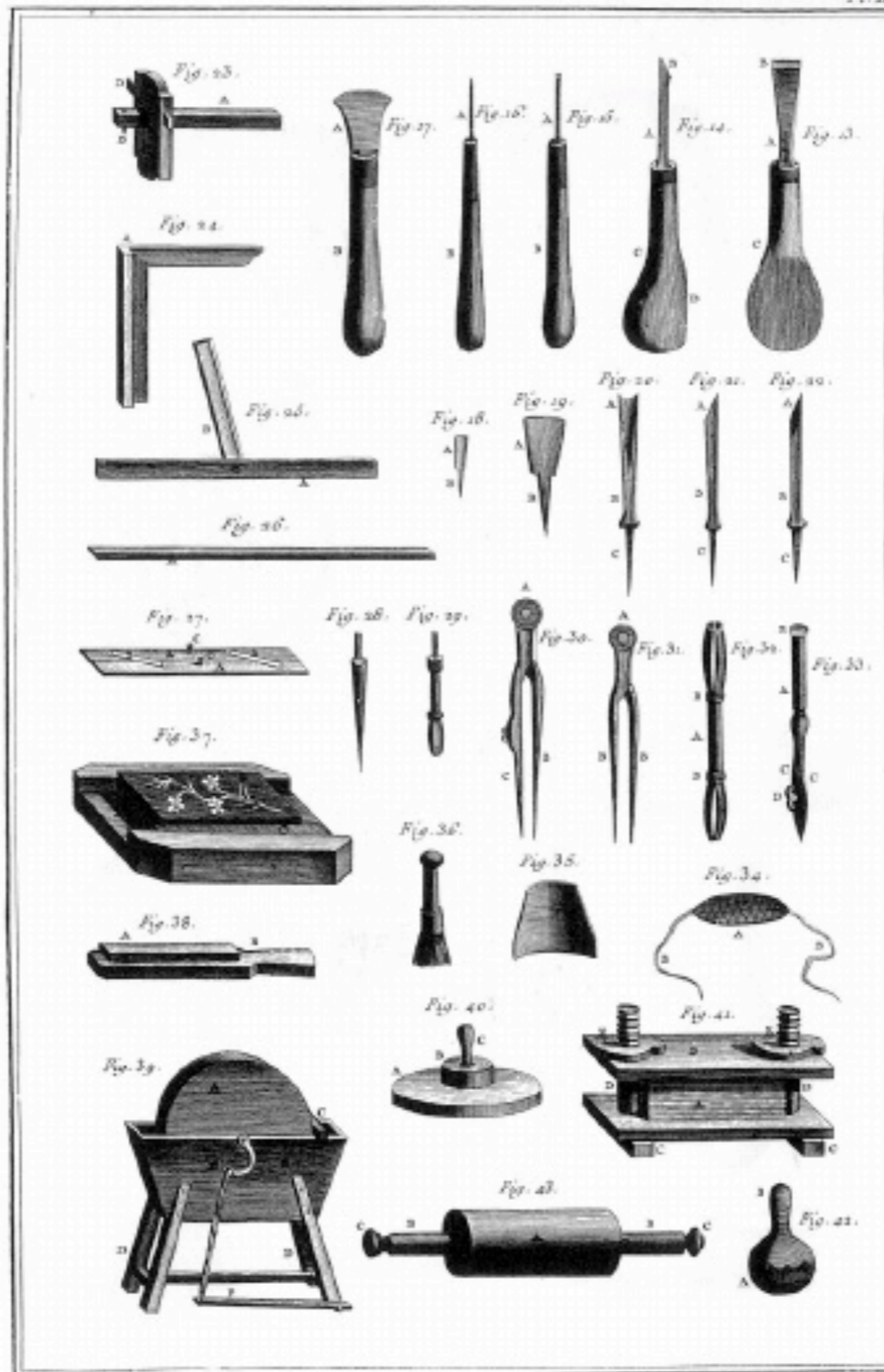

Gravure en Bois, outils.

“Gravure en Bois”
 The Encyclopedia of Diderot & d'Alembert 1763
 (University of Michigan Library)

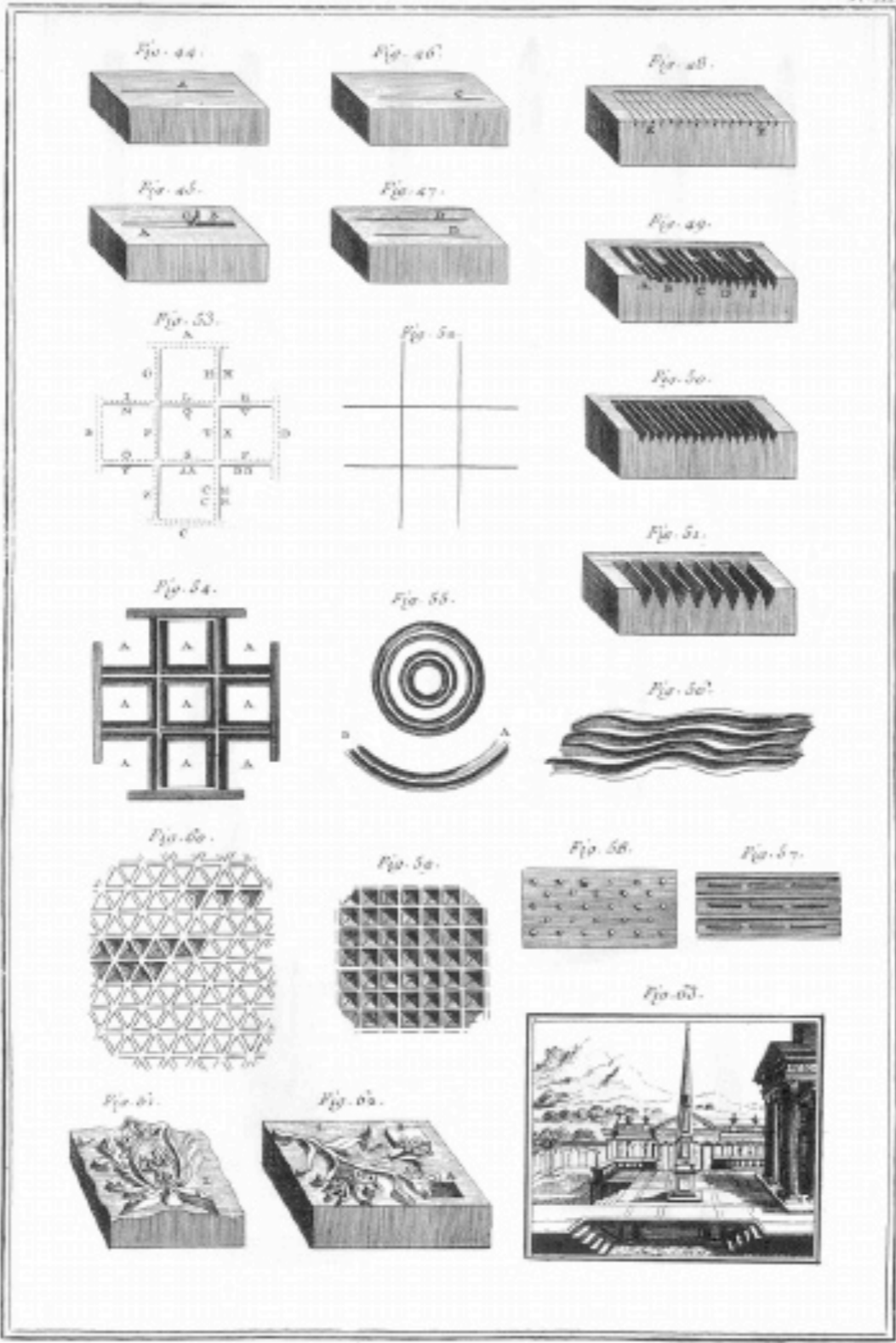

Gravure en Bois, Principes.

“Gravure en Bois”
 The Encyclopedia of Diderot & d'Alembert 1763
 (University of Michigan Library)

Wrenches



10 1/2" Wrought Iron Wrench
18th Century
(Jim Bode Tools)



5 3/4" European Wrench
18th Century
(Jim Bode Tools)

Pliers



6 3/4" Pliers
18th Century
(Jim Bode Tools)

Purfling Tools



5 1/2" Purfling Tool
18th Century
(Jim Bode Tools)

Vises
&
Clamps

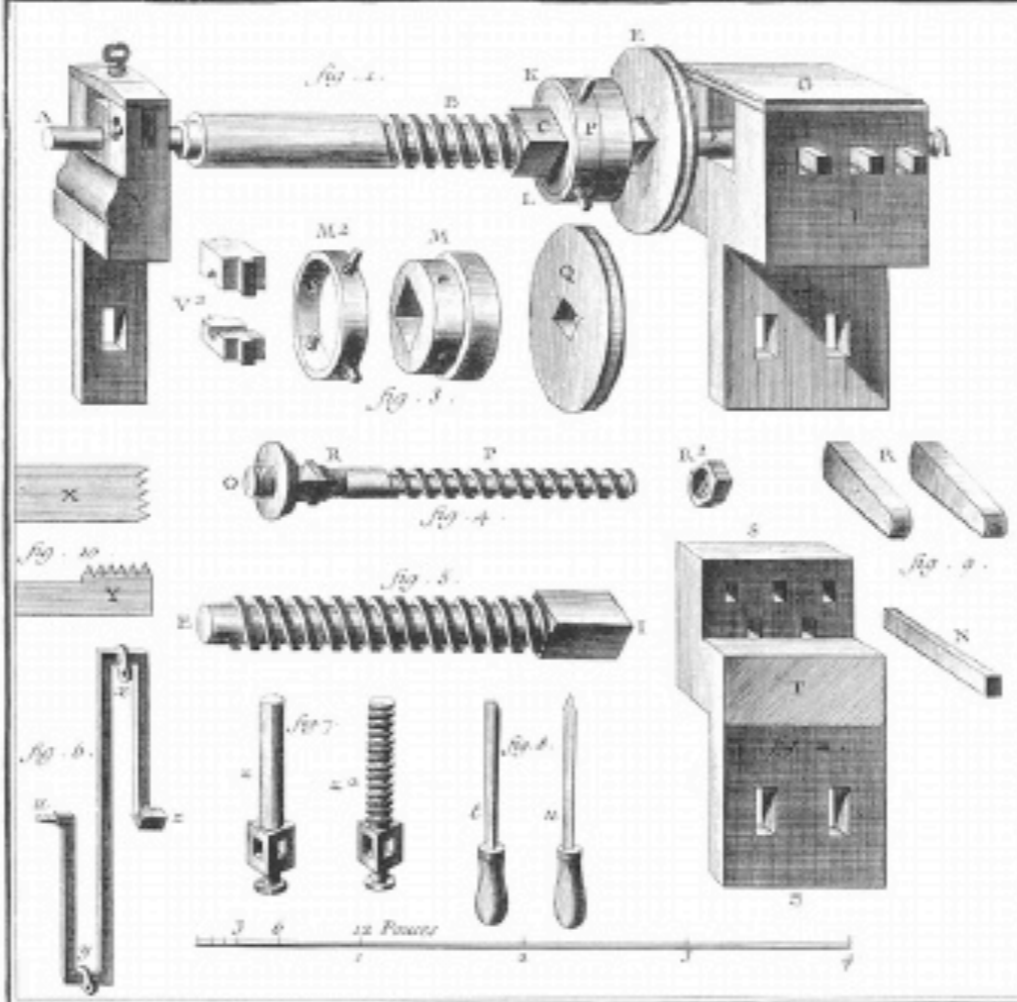
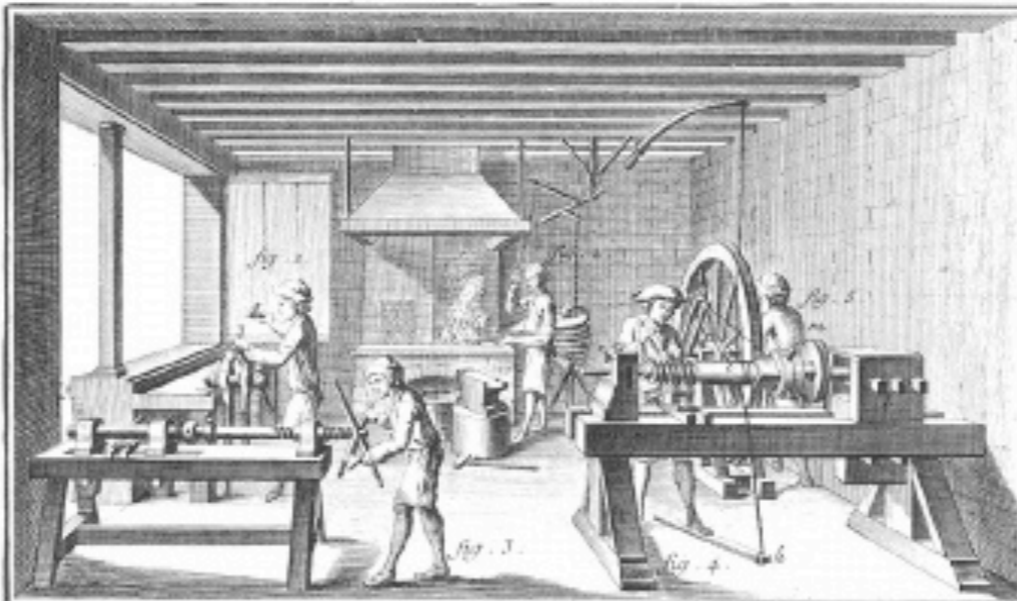

Benard del.

Benard fecit.

Taillanderie, Fabrique des Blancs.

“Taillanderie”
 The Encyclopedia of Diderot & d'Alembert 1763
 (University of Michigan Library)

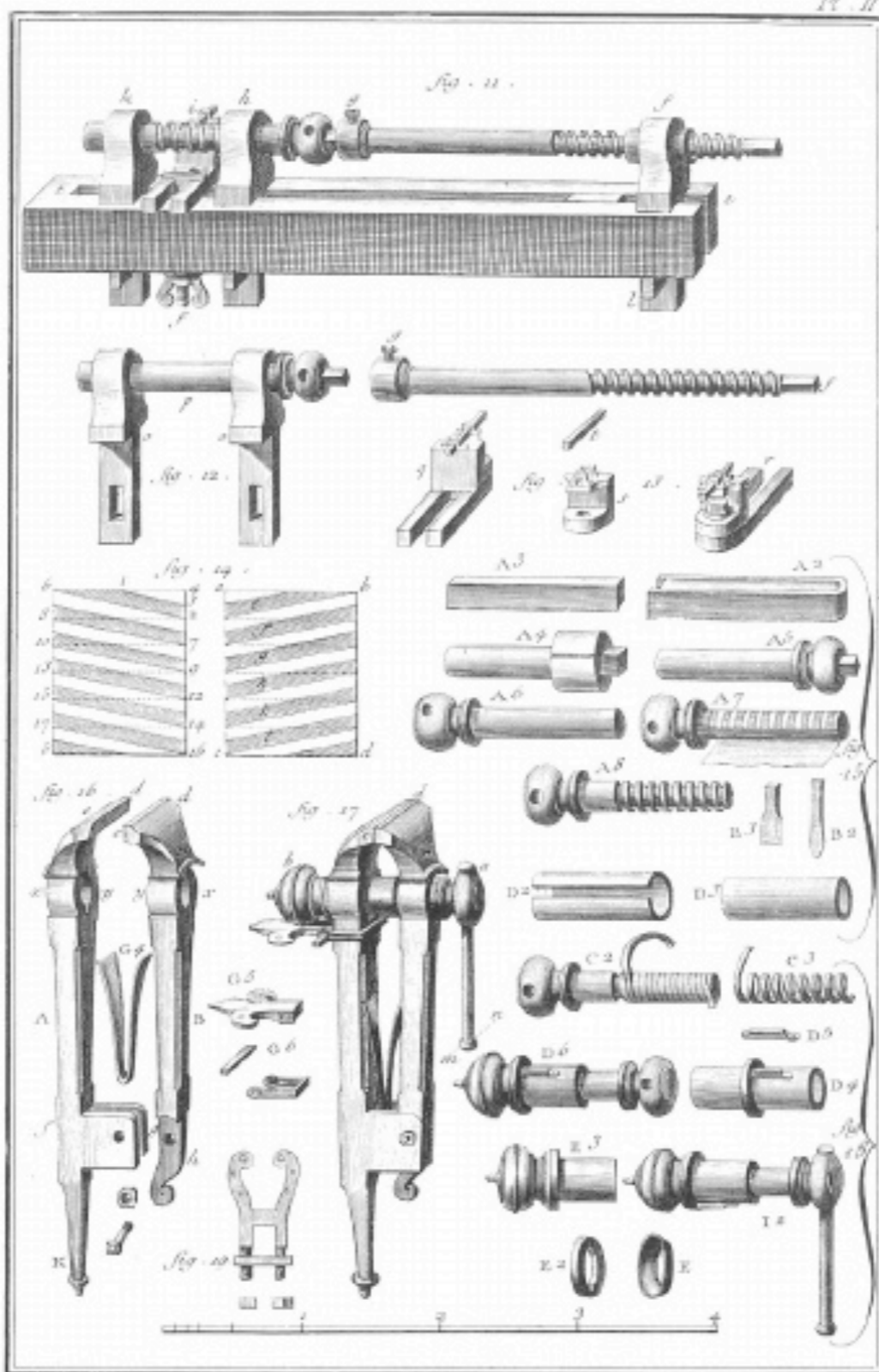

Benard del.

Benard fecit.

Taillanderie, suite de la fabrique des Eaux.

“Taillanderie”
 The Encyclopedia of Diderot & d'Alembert 1763
 (University of Michigan Library)

2.7.7.7. HAND-CLAMP / ŚCISK

W-32/635/95, CMM/BO/1828

Site location / Lokalizacja: 23P1.

Dimensions / Wymiary: length / długość
135 mm, width / szerokość 48 mm.

Two flat arms held together by a pivot with a head measuring 22 x 19 mm. There is a round, empty sleeve at the end of each arm.

Dwa płaskie ramiona połączone ze sobą przy pomocy trzpienia z łbem o wymiarach 22 x 19 mm, na końcach każdego ramienia znajduje się okrągła tulejka, pusta w środku.

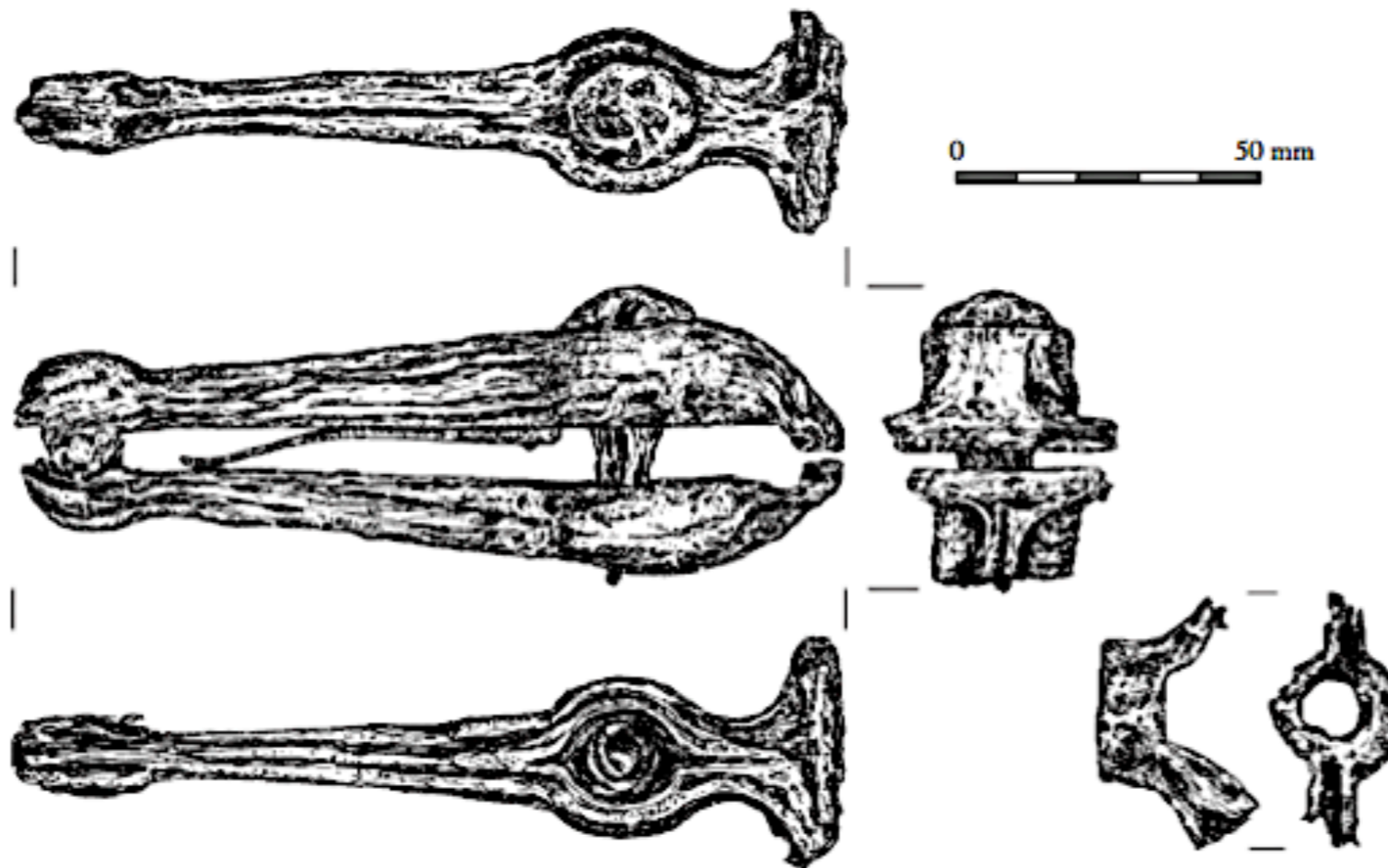

Gimlet. Recovered from the Wreck of the General Carleton of Whitby 1785

From: Ossowski, Waldemar, ed.; "The General Carleton Shipwreck, 1785."

Archaeological Research of the Polish Maritime Museum. Vol. I. Maritime Museum in Gdansk. Gdansk, Poland. 2008

Tweezers



Sheffield or Birmingham, England, Steel Tweezers
c. 1760 - 1820
(Colonial Williamsburg)

Glue Pots



English Copper Glue Pot & Inner Pot
c. 1775 - 1850
(Colonial Williamsburg)



Recreated Glue Pot
(The Joiner's Shop at Colonial Williamsburg)

Window Tools

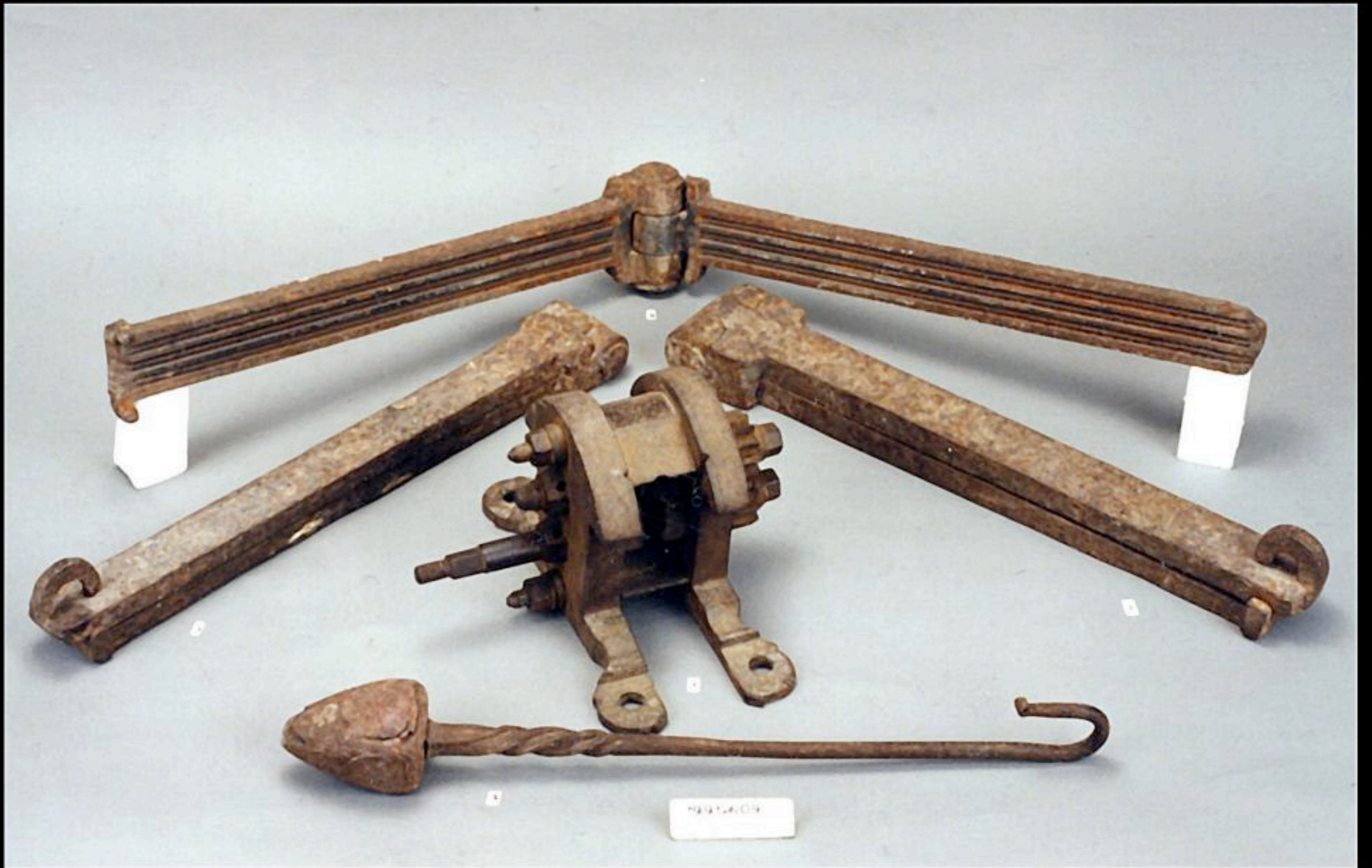

English Glazier's Rolling Mill for Lead Window Comes Used to Assemble Leaded Casement Windows
Dated 1755
(Colonial Williamsburg)

Acknowledgements

The material contained within these slideshows is presented for educational purposes only. The 18th Century Material Culture Resource Center does not personally own any of the items depicted herein and is indebted to the countless museums, libraries, and private collectors who willingly share their collections with the public through the internet. Every attempt has been made to credit these organizations and individuals for their contributions as best as possible.

If there is a question you have regarding a particular item featured within a presentation, please contact the 18th Century Material Culture Resource Center and we will try to answer your inquiry as best as possible. If for any reason you feel there is any item that should not be presented here, or if there is an error in any listing, or if you know the source for any item whose credit is unknown, please inform us and we will make sure your concern is addressed as soon as possible.

Thank you!

- The 18th Century Material Culture Resource Center